

LG

Single Indoor Unit

Heat pump, R410A

MFL67986347

TOTAL HVAC SOLUTION PROVIDER

ENGINEERING PRODUCT DATA BOOK

Single Indoor Unit
General Information

Model Line Up

1. Model Line Up

Product	Chassis	Capacity Index	Model Name
		kW	
Ceiling Cassette 1-Way	TT	5.3	ATNW18GTLP1
		7.0	ATNW24GTLP1
Ceiling Cassette 4-Way	TP	5.3	ATNW18GPLP1
		7.0	ATNW24GPLP1
	TN	10.6	ATNW36GNLP1
		TM	14.1
			17.6
	Ceiling Suspended	VM1	10.6
VM2		14.1	AVNW48GM2P1
		17.6	AVNW60GM2P1

* The capacity index may differ from actual capacity values.

**Single Indoor Unit
Product Data**

Ceiling Cassette 1-Way

Ceiling Cassette 4-Way

Ceiling Suspended

1. ATNW18GTLP1

1.1 Specifications

Category		Unit	Specification
Major	Minor		
Classification	Chassis	-	TT
Power Supply	Case 1	-	220, 1, 60
	Case 2	-	-
	Limit Range of Voltage(Case 1)	V	198 ~ 242
	Limit Range of Voltage(Case 2)	V	-
Cooling Capacity	Nominal	kW	4.69
		Btu/h	16,000
Heating Capacity	Nominal	kW	5.28
		Btu/h	18,000
Power Input(Indoor)	H/M/L	W	-
Running Current	H/M/L	A	-
Indoor Fan	Type	-	CFF
	Quantity	EA	1
	Air Flow Rate((SH)/H/M/L)	m ³ /min	- / 13.3 / 11.8 / 10.8
	Air Flow Rate Range(Min~Max)	m ³ /min	10.8~13.3
	External Static Pressure_Factory Set	Pa	-
Indoor Fan Motor	Type	-	BLDC
	Drive	-	-
	Output	W	30
		No.	1
Dehumidification Rate	-	ℓ/h	-
Heat Exchanger	Rows x Columns x FPI	-	2 x 12 x 18
	No.	-	1
	Fin Type	-	Slit(Half)
	Face Area	m ²	0.24
Dimensions	Net(W x H x D)	mm	1,180 x 132 x 450
	Shipping(W x H x D)	mm	1,445 x 252 x 538
Weight	Net	kg	14.5
	Shipping	kg	17.5
Exterior	Color	-	White
	RAL (Classic)	-	RAL 9003
Air Filter	Type	-	Long Life
Protection Device	Fuse	-	O
	Overload Protector for Fan Motor	-	Thermal Protector for Fan Motor
Refrigerant	Type	-	R410A
	Control Type	-	-
Drain Pipe(Natural Drainage)	O.D / I.D	mm(inch)	-
Drain Pipe(using Drain Pump)	O.D / I.D	mm(inch)	Φ32(1-1/4)/Φ25(31/32)
Pipe Connecting Socket	Liquid	mm(inch)	Φ6.35 (1/4)
	Gas	mm(inch)	Φ12.7 (1/2)
	Connection Type(Liquid)	-	Flare
	Connection Type(Gas)	-	Flare
Sound Pressure Level(Indoor Unit)	Cooling ((SH)/H/M/L)	dB(A)	- / 45.0 / 42.0 / 39.0
	Heating ((SH)/H/M/L)	dB(A)	- / 45.0 / 42.0 / 39.0
Measurement Standard (Pressure Level)	-	-	ISO 3745
Sound Power Level(Indoor Unit)	Cooling ((SH)/H/M/L)	dB(A)	-
	Heating ((SH)/H/M/L)	dB(A)	-
Measurement Standard (Power Level)	-	-	-
Connecting Cable	Power and Communication cable(H07RN-F)	mm ² × cores	0.75 x 4

1. ATNW18GTLP1

Category		Unit	Specification
Major	Minor		
Power Supply Type to Indoor	-	-	-
Electrical Characteristic	Indoor Fan Motor_Full Load Amperes (FLA)	A	0.6

Note

- Due to our policy of innovation some specifications may be changed without notification.
- Wiring cable size must comply with the applicable local and national code.
And "Electric characteristics" should be considered for electrical work and design.
- Especially the power cable and circuit breaker should be selected in accordance with that.
- Sound Level Values are measured at Noise Measuring chamber accordance with standard.
Therefore, these values depend on the ambient conditions and values are normally higher in actual operation.

1. ATNW18GTLP1

1.2 List of Functions

Category	Functions	Availability
Air Flow	Air Supply Outlet	1
	Airflow Direction Control (left & right)	Auto
	Airflow Direction Control (up & down)	Auto
	Auto Swing (left & right)	O
	Auto Swing (up & down)	O
	Airflow Steps (fan/cool/heat)	4 / 5 / 4
	Fan Speed Auto*	Advanced
	Power Cool/Heat	O / X
	Swirl Wind*	X
	Refresh Mode**	X
	Smart Mode**	X
	Indirect Wind*	O
	Direct Wind*	O
	Dry Operation	O
Air Purification	Air Purify	Accessory
	Ionizer	X
	UV-C	X
	Allergy Filter	X
	Pre-Filter	O
	PM1.0 Filter	X
Reliability	Hot Start	O
	Self Diagnosis	O
Convenience	Auto Mode	O
	Auto Dry Operation**	O
	Auto Restart	O
	Child Lock*	O
	Forced Operation	O
	Group Control*	O
	Sleep Timer**	O
	Turn On/Off Reservation**	O
	Schedule**	O
	Two Thermistor Control*	O
	Time Limit Control (Energy saving)***	O
External On/Off	O	
Installation	Drain Pump	O
	High Ceiling Operation*	O
Special Functions	Wi-Fi Control	Accessory
	Comfort Cooling (Humidity Control)***	O
	Auto Elevation Grille	X
	Human Detection Function***	X
	Floor Detection Function***	X

Note

- O : Applied, X : Not Applied, - : Unconfirmed or irrelevant
- Embedded : A kit is provided by default for using this function when the product is manufactured.
- Accessory : Ordered and purchased separately the accessory package referring to the model name provided and install at field.
- Accessory line-ups varies by region, so check your local catalogue or local sales material.
- Some functions can be limited by remote controller.
- In case of cassette type indoor units, Plasma kit and Auto Elevation Grille functions are not applicable at the same time.
- 'Auto Mode' varies depending on the outdoor unit type.
 - Auto Change Over(Single Heat Pump Outdoor Unit)
 - Auto Mode Select(Multi Heat Pump Outdoor Unit)

1. ATNW18GTLP1

- Auto Intensity Control(Cooling Only Outdoor Unit)
- * : These functions need to connect the wired remote controller.
- ** : This functions need to connect to the Standard II / III wired remote controller.
- *** : This functions need to connect to the Standard III wired remote controller.

1. ATNW18GTLP1

1.3 Accessory Compatibility List

Category	Accessory Name	Model Name	Description	Compatibility
Remote Controller	Wired - Premium	PREMTA000	-	O
		PREMTA000A	-	O
		PREMTA000B	-	O
	Wired - RS3 (Standard III)	PREMTB100	White	O
		CREMTB100	White	O
		PREMTBB10	Black	O
	Wired - RS2 (Standard II)	PREMTB001	White	O
		CREMTB001	White	O
		PREMTBB01	Black	O
	Wired - Simple	PQRCVCL0QW	White	O
		PQRCVCL0Q	Black	O
	Wired - Simple for hotel	PQRCHCA0QW	White	O
		PQRCHCA0Q	Black	O
	Wireless	PQWRCQ0FDB	For Cooling only	X
		PQWRHQ0FDB	For Heat pump	O
		PWLSSB21C	For Cooling only	X
PWLSSB21H		For Heat pump	O	
Dry Contact	Simple	PDRYCB000	1 input port, AC 220 - 240V	O
		PDRYCB100	1 input port, AC 24V	O
	Communication	PDRYCB400	2 input port	O
		PDRYCB300	8 input port, For 3rd party Thermostat	O
		PDRYCB320	8 input port, For 3rd Party Thermostat (Analog Input)	O
PDRYCB500	For 3rd Party Controller(Modbus RTU)	X		
Integration Device	Remote Temperature sensor	PQRSTA0	-	O
	Group Control wire	PZCWRCG3	Cable Assembly for group control (Y-type cable : 0.25m, cable : 9.6m)	O
ETC	Extension wire	PZCWRC1	Extension wire for IDU-wired remote controller (9.6m)	X
	2-Remo Control wire	PZCWRC2	-	X
	Wi-Fi Modem	PWFMD200	-	O
	Wi-Fi Extension cable	PWYREW000	USB Extension cable : 10 m	X
	Independent Power Module	PRIP0	For Multi V Indoor Unit	X
	Multi-tenant Power module	PINPMB001	For Multi V Indoor Unit	X
	Refrigerant Leakage Detector	PRLDNVS0	For Multi V Indoor Unit (R410A)	X
	Human Detection Sensor	PTVSMA0	For Cassette 4-way	X
		PTVSA0	For Cassette Dual Vane 4-way	X
	Floor Detection Sensor	PTFSMA0	For Cassette Dual Vane 4-way	X
	Auto Elevation Grille	PTEGM0	For Cassette 4-way	X
	Air Purification Kit	PTAHTP0	For Cassette 1-way	O
		PTAHMP0	For Cassette 4-way	X
		PTAHYP0	For Cassette Round	X
	EEV Kit	PRGK024A0	For Multi V Indoor Unit	X
	Auxiliary Heater Relay Kit	PRARS1	For Wall Mounted / Art Cool Indoor Units	X
		PRARH1	For Cassette / Duct Indoor Units	X
	Ventilation Kit	PTVK430	For TR/TQ/TP/TN/TM Chassis	X
		PTVK410 / PTVK420	For TP/TN/TM Chassis	X
	Cassette Cover	PTDCQ	For TR/TQ Chassis	X
PTDCM		For TP/TN/TM Chassis	X	
PTDCA		For TM-A/TP-B Chassis	X	

Note

- O: Possible, X: Impossible, -: Unconfirmed or irrelevant.
- *: Some advanced functions controlled by individual controller cannot be operated.
- Air Purification Kit and Auto Elevation Grille are not applicable at the same time.

1. ATNW18GTLP1

- If there is a difference in development time between the product and the remote controller, some functions cannot be operated.
- If you need more detail, please refer to the Control(BECON) PDB or the manual of product.
(<http://partner.lge.com/global> : Home> Doc.Library> Product > Control(BECON)).

1. ATNW18GTLP1

1.4.2 Product_Panel : PT-TAHG0

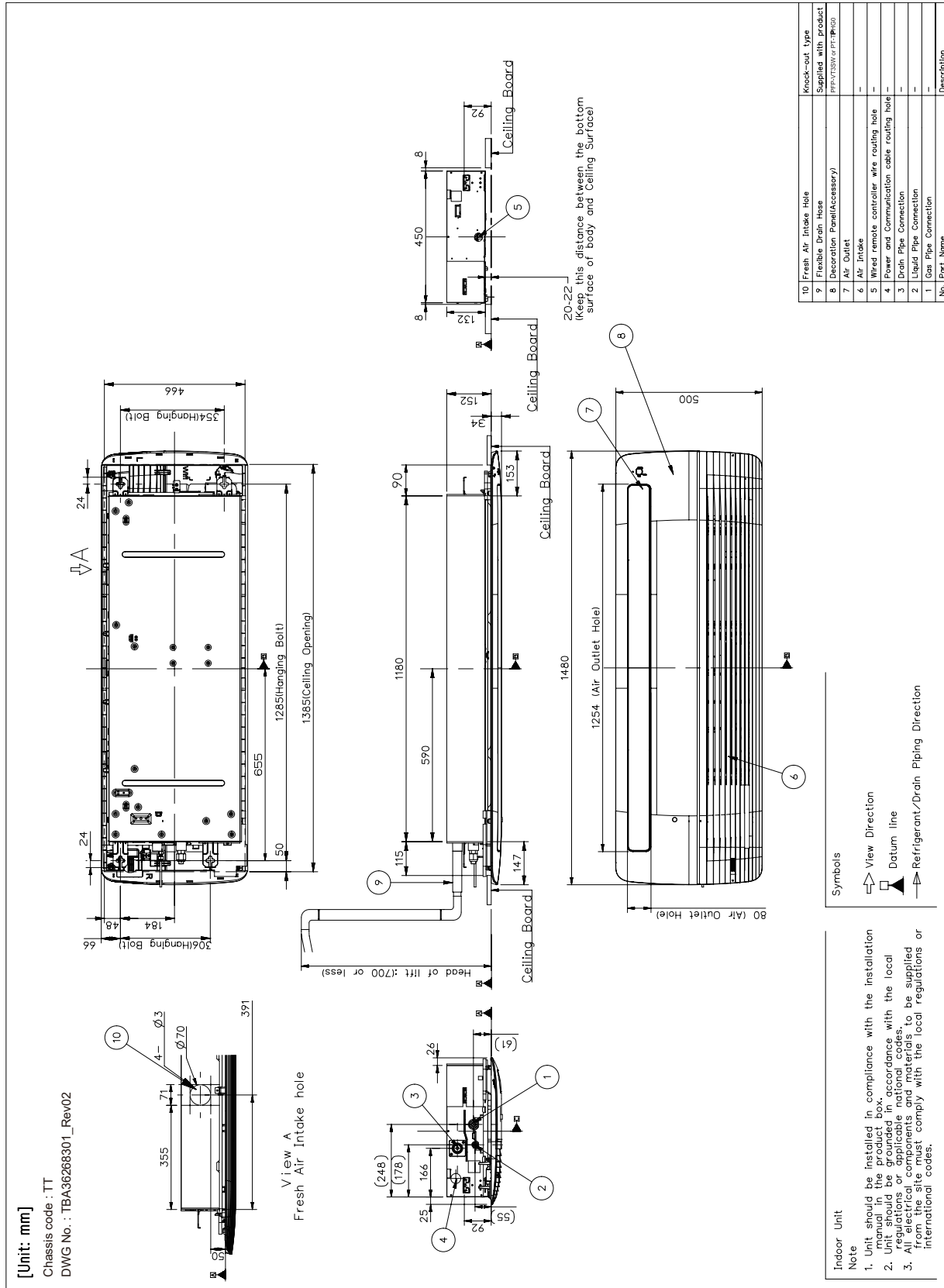

1. ATNW18GTLP1

1.4.3 Product_Panel : PT-TPHG0

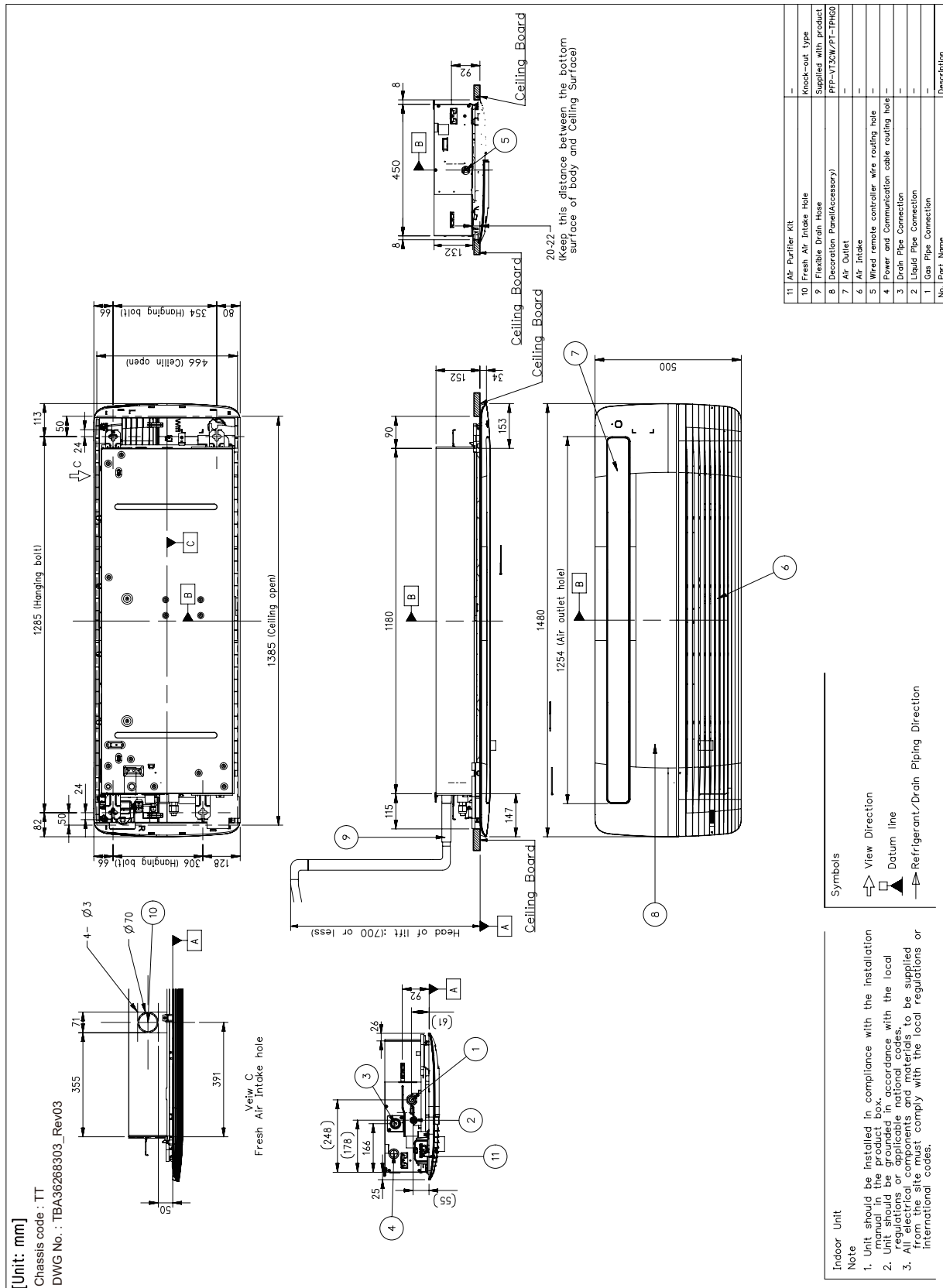

1. ATNW18GTLP1

1.4.4 Install Space

< Minimum Installation Space >

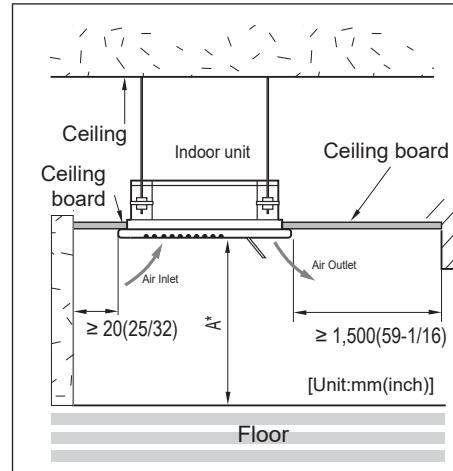
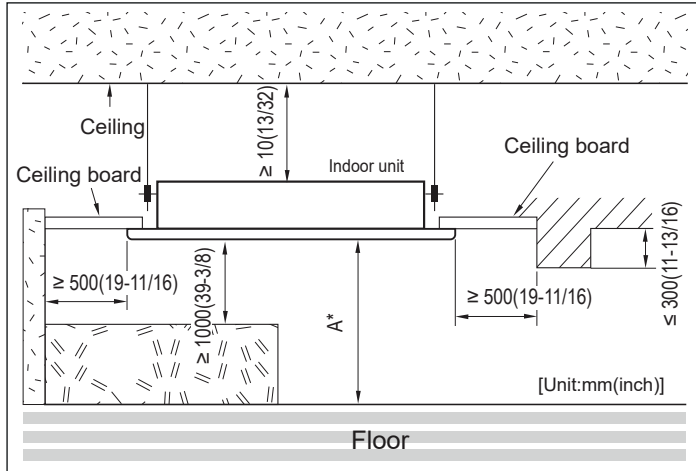

Notes

1. * : A, Installation Height from the floor

Type	Installation Height (A)		
	Min.	Standard **	Max.
Ceiling Mounted Cassette 1Way	1.8 m (5.91 ft)	2.7 m (8.86 ft)	3.3 m (9.84 ft)

** : Standard Height (Recommended)

If it exceeds the standard height, set the 'High Ceiling Mode'.

For details about function setting, refer to the installation manual.

< Cautions for Panel installation >

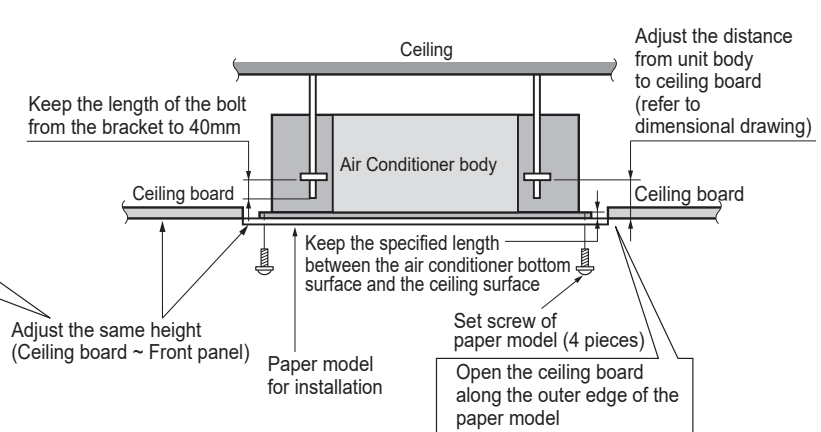
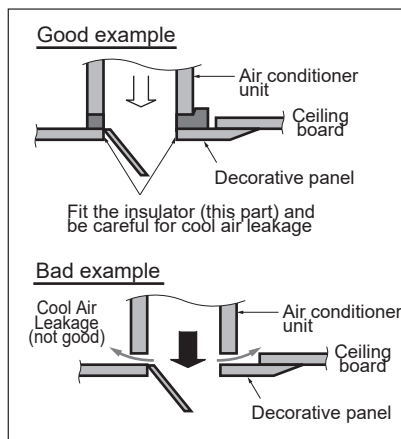

Note

- Places where products are installed should not be any obstacles to the air circulation or installation. Ensure the spaces from the wall, ceiling, or other obstacles.
- According to type of indoor unit, external appearance or installed structure could be different.
- According to product type, model line up, sales region..etc, applicability of each chassis could be different.
- Install certainly the decoration panel. Cool air leakage causes sweating or falling of water-drops.

1. ATNW18GTLP1

1.5 Piping Diagrams

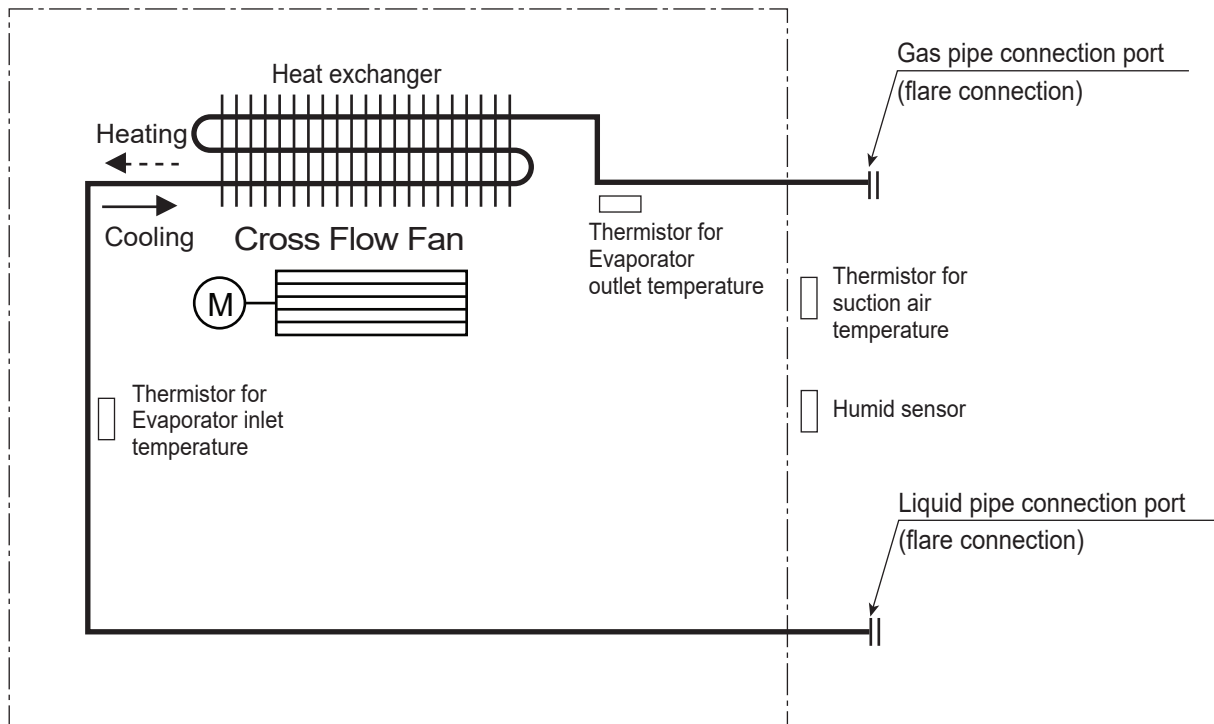

1. ATNW18GTLP1

1.6 Wiring Diagrams

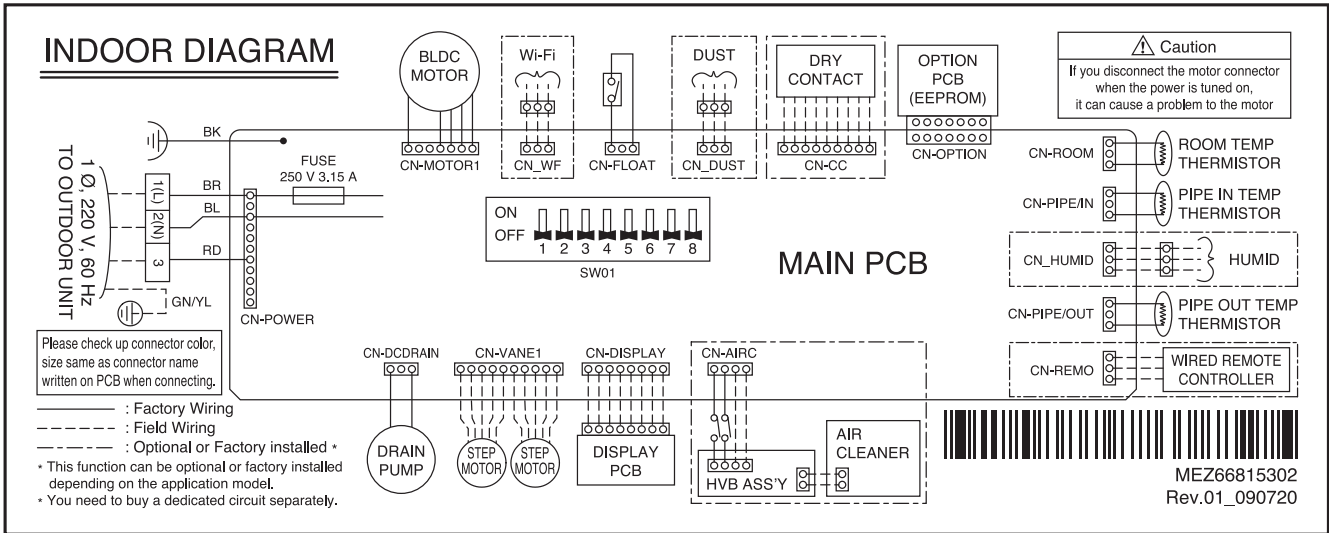

1. ATNW18GTLP1

1.7 Sound Levels

1.7.1 Pressure Levels

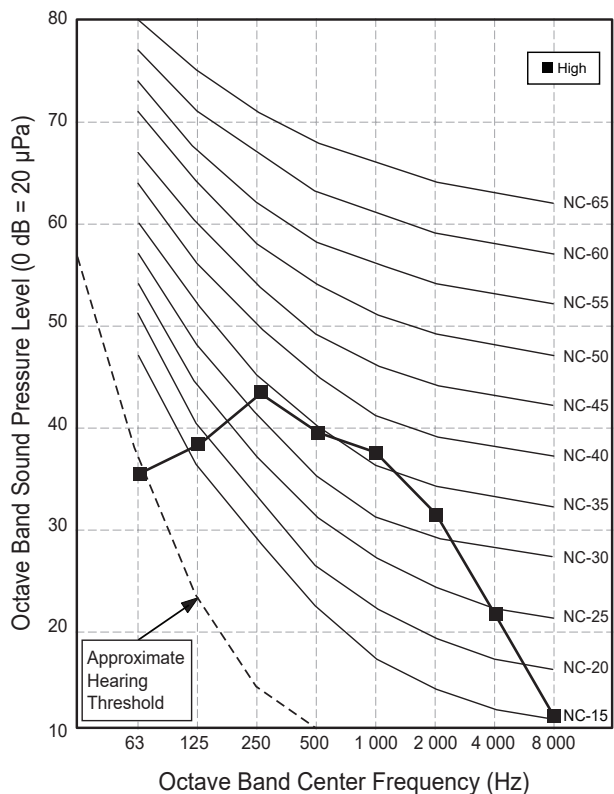

Sound level [dB(A), @ Standard condition]	
Cooling ((SH)/H/M/L)	- / 45.0 / 42.0 / 39.0
Heating ((SH)/H/M/L)	- / 45.0 / 42.0 / 39.0

Note

- Sound measured at some distance away from the center of the unit.
- Data is valid at free field condition.
- Reference acoustic pressure 0dB = 20µPa.
- Data is valid at nominal operation condition.
Refer to the Model Specifications for nominal conditions(Power source and Ambient temperature, etc)
- Sound levels can be increased in accordance with installation and operating conditions.
(Static pressure mode, used air guide, Room target temperature setting, etc)
- Sound pressure level is measured on the rated condition in the anechoic rooms by ISO 3745 standard.
Therefore, these values can be increased owing to ambient conditions during operation.

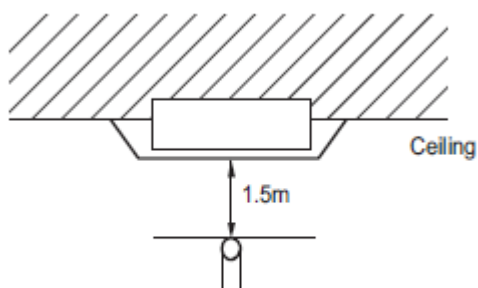

* Measuring place : Anechoic chamber

1. ATNW18GTL P1

1.8 Air flow and temperature distributions

1.8.1 Cooling operation

Discharge angle: 50°

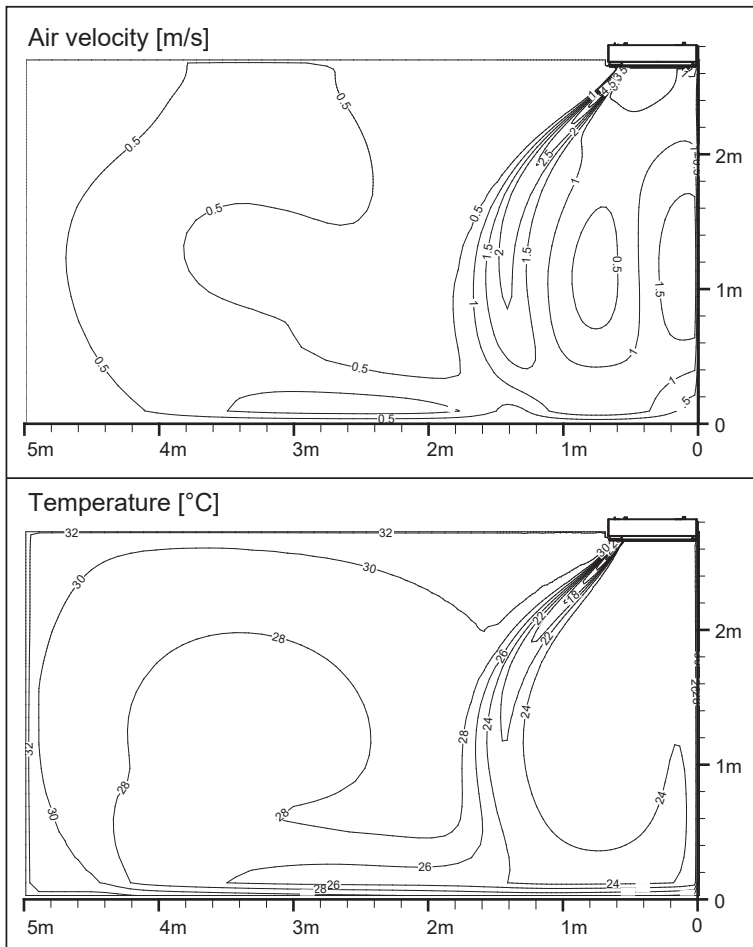

Note

- These figures are accordance with normal certain condition and environment. (Airflow step is 'High', Air discharge angle is fixed as indicated angle.)
- Indoor airflow distribution under actual installation or operating conditions depends on ambient temperature, ceiling height, product installation direction / location, indoor / Heating load, and other obstacles, etc.

1. ATNW18GTLP1

1.8.2 Heating operation

Discharge angle: 60°

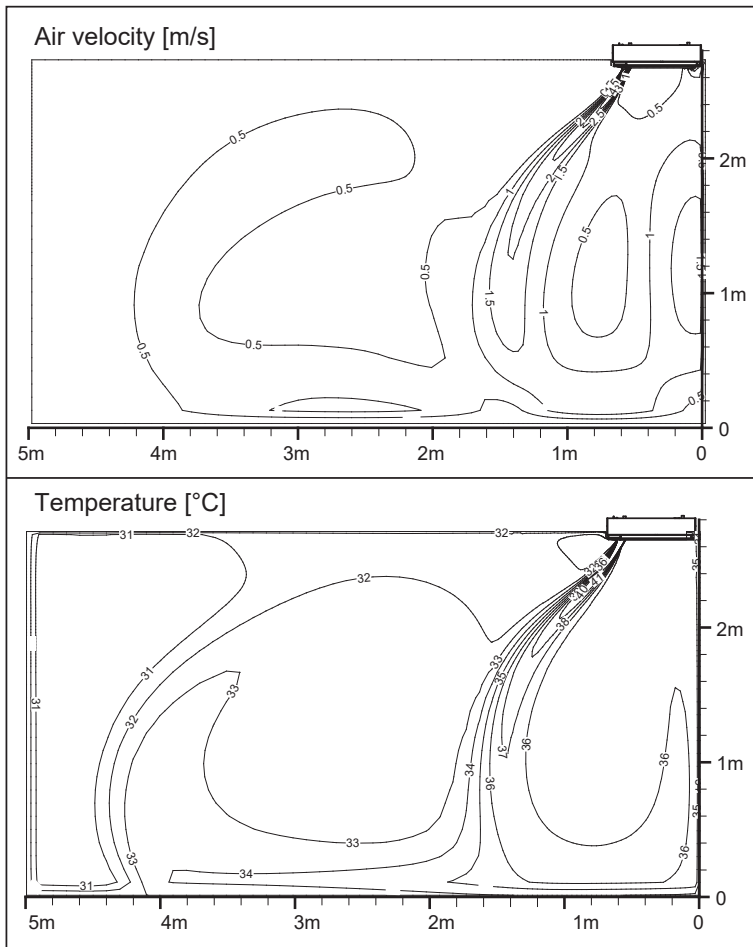

Note

- These figures are accordance with normal certain condition and environment.
(Airflow step is 'High', Air discharge angle is fixed as indicated angle.)
- Indoor airflow distribution under actual installation or operating conditions depends on ambient temperature, ceiling height, product installation direction / location, indoor / Heating load, and other obstacles, etc.

2. ATNW24GTLP1

2.1 Specifications

Category		Unit	Specification
Major	Minor		
Classification	Chassis	-	TT
Power Supply	Case 1	-	220, 1, 60
	Case 2	-	-
	Limit Range of Voltage(Case 1)	V	198 ~ 242
	Limit Range of Voltage(Case 2)	V	-
Cooling Capacity	Nominal	kW	6.16
		Btu/h	21,000
Heating Capacity	Nominal	kW	6.74
		Btu/h	23,000
Power Input(Indoor)	H/M/L	W	-
Running Current	H/M/L	A	-
Indoor Fan	Type	-	CFF
	Quantity	EA	1
	Air Flow Rate((SH)/H/M/L)	m ³ /min	- / 16.0 / 14.0 / 12.0
	Air Flow Rate Range(Min~Max)	m ³ /min	12.0~16.0
	External Static Pressure_Factory Set	Pa	-
Indoor Fan Motor	Type	-	BLDC
	Drive	-	-
	Output	W	30
		No.	1
Dehumidification Rate	-	ℓ/h	-
Heat Exchanger	Rows x Columns x FPI	-	2 x 12 x 18
	No.	-	1
	Fin Type	-	Slit(Half)
	Face Area	m ²	0.24
Dimensions	Net(W x H x D)	mm	1,180 x 132 x 450
	Shipping(W x H x D)	mm	1,445 x 252 x 538
Weight	Net	kg	14.5
	Shipping	kg	17.5
Exterior	Color	-	White
	RAL (Classic)	-	RAL 9003
Air Filter	Type	-	Long Life
Protection Device	Fuse	-	O
	Overload Protector for Fan Motor	-	Thermal Protector for Fan Motor
Refrigerant	Type	-	R410A
	Control Type	-	-
Drain Pipe(Natural Drainage)	O.D / I.D	mm(inch)	-
Drain Pipe(using Drain Pump)	O.D / I.D	mm(inch)	Φ32(1-1/4)/Φ25(31/32)
Pipe Connecting Socket	Liquid	mm(inch)	Φ9.52 (3/8)
	Gas	mm(inch)	Φ15.88 (5/8)
	Connection Type(Liquid)	-	Flare
	Connection Type(Gas)	-	Flare
Sound Pressure Level(Indoor Unit)	Cooling ((SH)/H/M/L)	dB(A)	- / 46.0 / 43.0 / 40.0
	Heating ((SH)/H/M/L)	dB(A)	- / 46.0 / 43.0 / 40.0
Measurement Standard (Pressure Level)	-	-	ISO 3745
Sound Power Level(Indoor Unit)	Cooling ((SH)/H/M/L)	dB(A)	-
	Heating ((SH)/H/M/L)	dB(A)	-
Measurement Standard (Power Level)	-	-	-
Connecting Cable	Power and Communication cable(H07RN-F)	mm ² × cores	0.75 x 4

2. ATNW24GTLP1

Category		Unit	Specification
Major	Minor		
Power Supply Type to Indoor	-	-	-
Electrical Characteristic	Indoor Fan Motor_Full Load Amperes (FLA)	A	0.6

Note

- Due to our policy of innovation some specifications may be changed without notification.
- Wiring cable size must comply with the applicable local and national code.
And "Electric characteristics" should be considered for electrical work and design.
- Especially the power cable and circuit breaker should be selected in accordance with that.
- Sound Level Values are measured at Noise Measuring chamber accordance with standard.
Therefore, these values depend on the ambient conditions and values are normally higher in actual operation.

2. ATNW24GTLP1

2.2 List of Functions

Category	Functions	Availability
Air Flow	Air Supply Outlet	1
	Airflow Direction Control (left & right)	Auto
	Airflow Direction Control (up & down)	Auto
	Auto Swing (left & right)	O
	Auto Swing (up & down)	O
	Airflow Steps (fan/cool/heat)	4 / 5 / 4
	Fan Speed Auto*	Advanced
	Power Cool/Heat	O / X
	Swirl Wind*	X
	Refresh Mode**	X
	Smart Mode**	X
	Indirect Wind*	O
	Direct Wind*	O
	Dry Operation	O
Air Purification	Air Purify	Accessory
	Ionizer	X
	UV-C	X
	Allergy Filter	X
	Pre-Filter	O
	PM1.0 Filter	X
Reliability	Hot Start	O
	Self Diagnosis	O
Convenience	Auto Mode	O
	Auto Dry Operation**	O
	Auto Restart	O
	Child Lock*	O
	Forced Operation	O
	Group Control*	O
	Sleep Timer**	O
	Turn On/Off Reservation**	O
	Schedule**	O
	Two Thermistor Control*	O
	Time Limit Control (Energy saving)***	O
External On/Off	O	
Installation	Drain Pump	O
	High Ceiling Operation*	O
Special Functions	Wi-Fi Control	Accessory
	Comfort Cooling (Humidity Control)***	O
	Auto Elevation Grille	X
	Human Detection Function***	X
	Floor Detection Function***	X

Note

- O : Applied, X : Not Applied, - : Unconfirmed or irrelevant
- Embedded : A kit is provided by default for using this function when the product is manufactured.
- Accessory : Ordered and purchased separately the accessory package referring to the model name provided and install at field.
- Accessory line-ups varies by region, so check your local catalogue or local sales material.
- Some functions can be limited by remote controller.
- In case of cassette type indoor units, Plasma kit and Auto Elevation Grille functions are not applicable at the same time.
- 'Auto Mode' varies depending on the outdoor unit type.
 - Auto Change Over(Single Heat Pump Outdoor Unit)
 - Auto Mode Select(Multi Heat Pump Outdoor Unit)

2. ATNW24GTLP1

- Auto Intensity Control(Cooling Only Outdoor Unit)
- * : These functions need to connect the wired remote controller.
- ** : This functions need to connect to the Standard II / III wired remote controller.
- *** : This functions need to connect to the Standard III wired remote controller.

2. ATNW24GTLP1

2.3 Accessory Compatibility List

Category	Accessory Name	Model Name	Description	Compatibility
Remote Controller	Wired - Premium	PREMTA000	-	O
		PREMTA000A	-	O
		PREMTA000B	-	O
	Wired - RS3 (Standard III)	PREMTB100	White	O
		CREMTB100	White	O
		PREMTBB10	Black	O
	Wired - RS2 (Standard II)	PREMTB001	White	O
		CREMTB001	White	O
		PREMTBB01	Black	O
	Wired - Simple	PQRCVCL0QW	White	O
		PQRCVCL0Q	Black	O
	Wired - Simple for hotel	PQRCHCA0QW	White	O
		PQRCHCA0Q	Black	O
	Wireless	PQWRCQ0FDB	For Cooling only	X
		PQWRHQ0FDB	For Heat pump	O
		PWLSSB21C	For Cooling only	X
PWLSSB21H		For Heat pump	O	
Dry Contact	Simple	PDRYCB000	1 input port, AC 220 - 240V	O
		PDRYCB100	1 input port, AC 24V	O
	Communication	PDRYCB400	2 input port	O
		PDRYCB300	8 input port, For 3rd party Thermostat	O
		PDRYCB320	8 input port, For 3rd Party Thermostat (Analog Input)	O
PDRYCB500	For 3rd Party Controller(Modbus RTU)	X		
Integration Device	Remote Temperature sensor	PQRSTA0	-	O
	Group Control wire	PZCWRCG3	Cable Assembly for group control (Y-type cable : 0.25m, cable : 9.6m)	O
ETC	Extension wire	PZCWRC1	Extension wire for IDU-wired remote controller (9.6m)	X
	2-Remo Control wire	PZCWRC2	-	X
	Wi-Fi Modem	PWFMD200	-	O
	Wi-Fi Extension cable	PWYREW000	USB Extension cable : 10 m	X
	Independent Power Module	PRIP0	For Multi V Indoor Unit	X
	Multi-tenant Power module	PINPMB001	For Multi V Indoor Unit	X
	Refrigerant Leakage Detector	PRLDNVS0	For Multi V Indoor Unit (R410A)	X
	Human Detection Sensor	PTVSMA0	For Cassette 4-way	X
		PTVSA0	For Cassette Dual Vane 4-way	X
	Floor Detection Sensor	PTFSMA0	For Cassette Dual Vane 4-way	X
	Auto Elevation Grille	PTEGM0	For Cassette 4-way	X
	Air Purification Kit	PTAHTP0	For Cassette 1-way	O
		PTAHMP0	For Cassette 4-way	X
		PTAHYP0	For Cassette Round	X
	EEV Kit	PRGK024A0	For Multi V Indoor Unit	X
	Auxiliary Heater Relay Kit	PRARS1	For Wall Mounted / Art Cool Indoor Units	X
		PRARH1	For Cassette / Duct Indoor Units	X
	Ventilation Kit	PTVK430	For TR/TQ/TP/TN/TM Chassis	X
		PTVK410 / PTVK420	For TP/TN/TM Chassis	X
	Cassette Cover	PTDCQ	For TR/TQ Chassis	X
PTDCM		For TP/TN/TM Chassis	X	
PTDCA		For TM-A/TP-B Chassis	X	

Note

- O: Possible, X: Impossible, -: Unconfirmed or irrelevant.
- * : Some advanced functions controlled by individual controller cannot be operated.
- Air Purification Kit and Auto Elevation Grille are not applicable at the same time.

2. ATNW24GTLP1

- If there is a difference in development time between the product and the remote controller, some functions cannot be operated.
- If you need more detail, please refer to the Control(BECON) PDB or the manual of product.
(<http://partner.lge.com/global> : Home> Doc.Library> Product > Control(BECON)).

2. ATNW24GTLP1

2.4 Dimensions

2.4.1 Product_Panel : PT-UTC

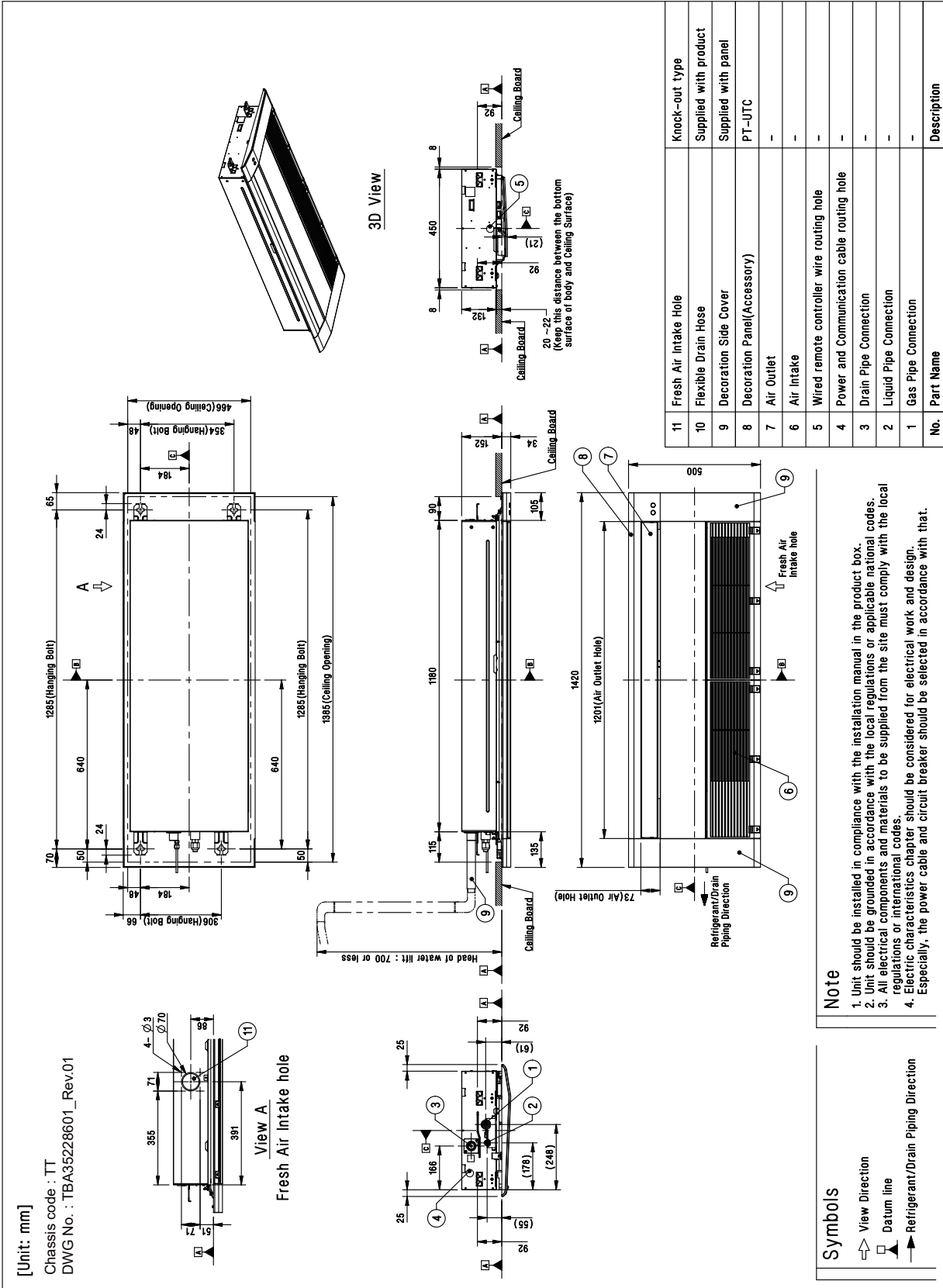

2. ATNW24GTLP1

2.4.2 Product_Panel : PT-TAHG0

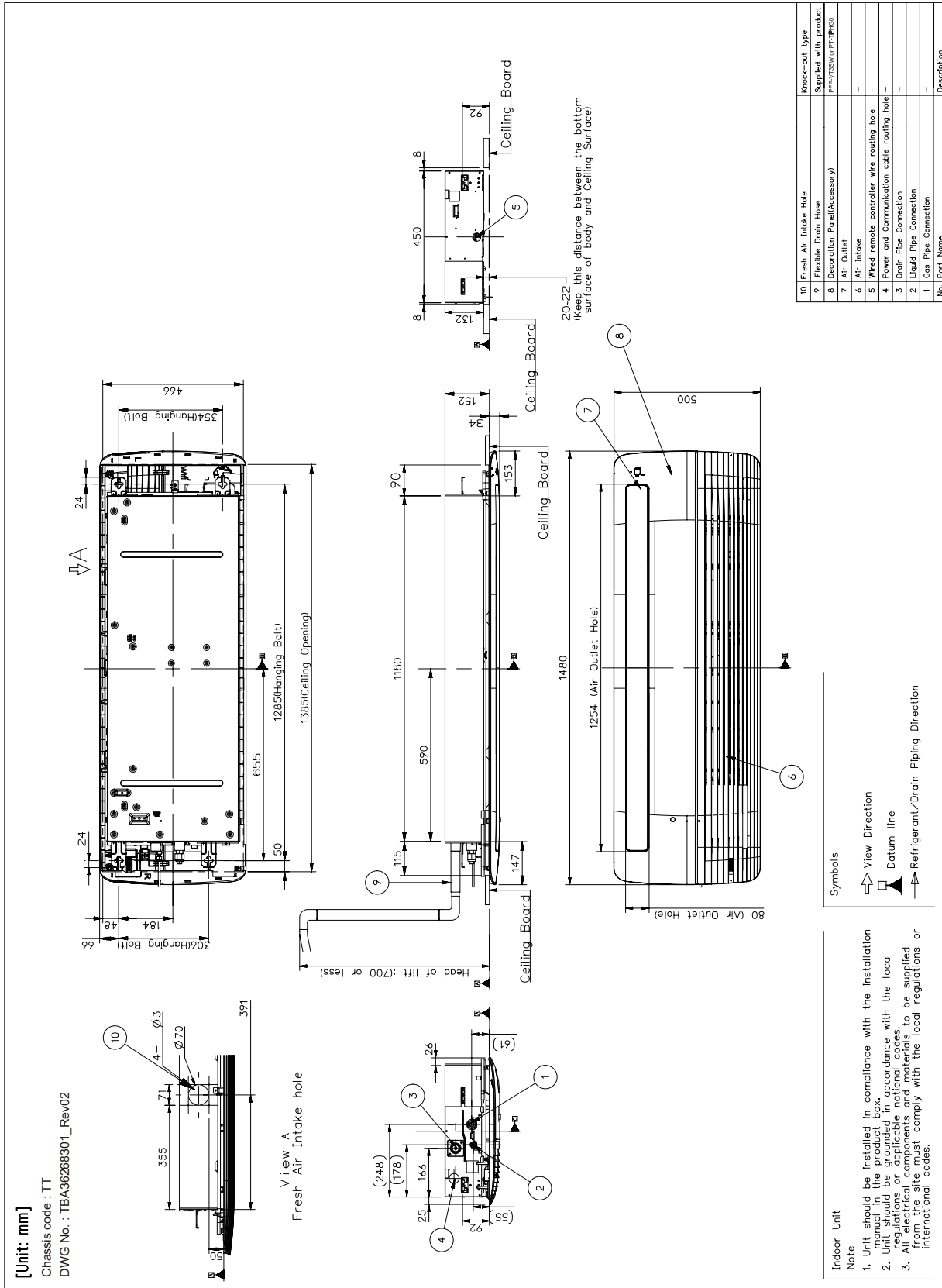

2. ATNW24GTLP1

2.4.3 Product_Panel : PT-TPHG0

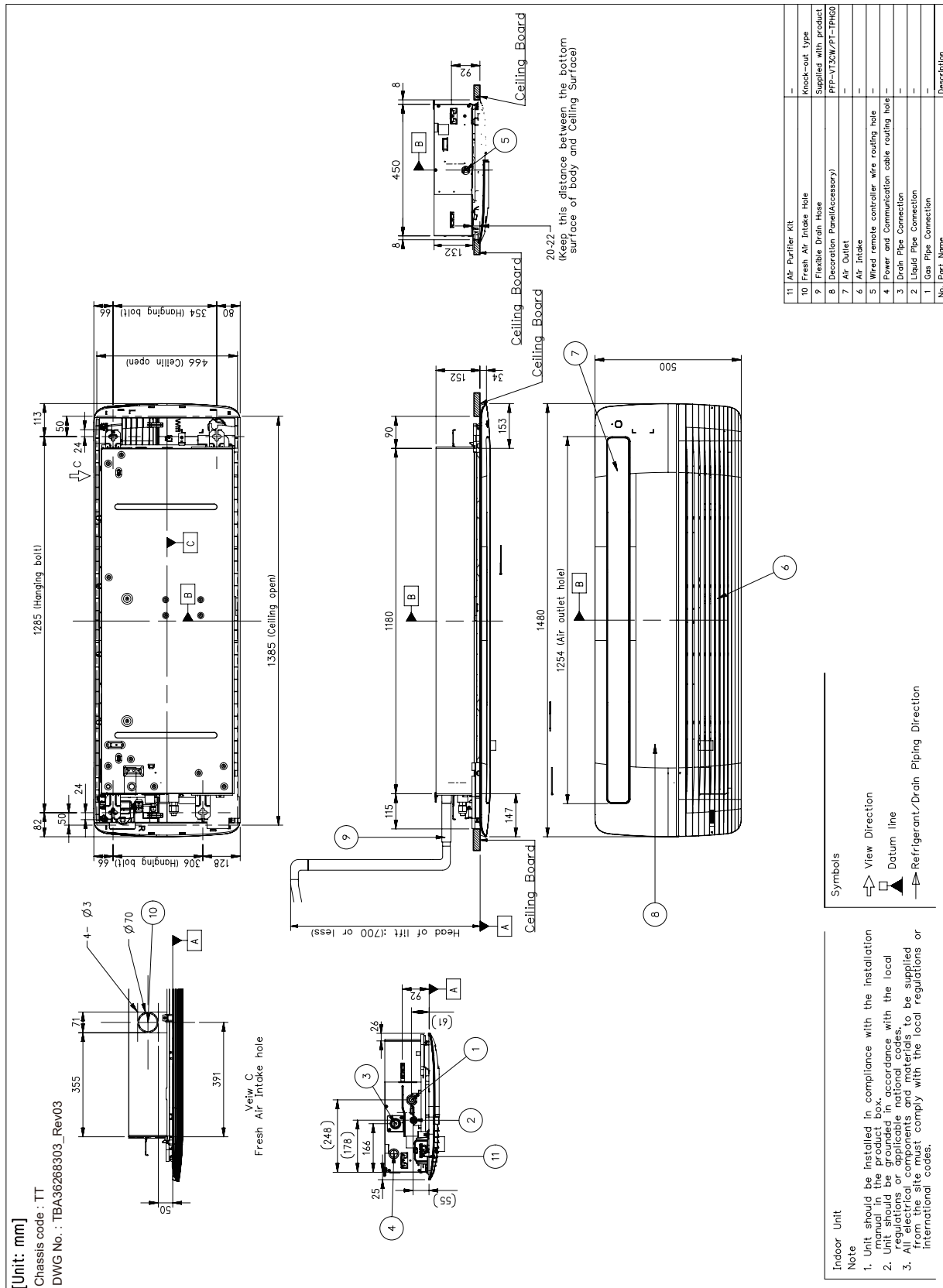

2. ATNW24GTLP1

2.4.4 Install Space

< Minimum Installation Space >

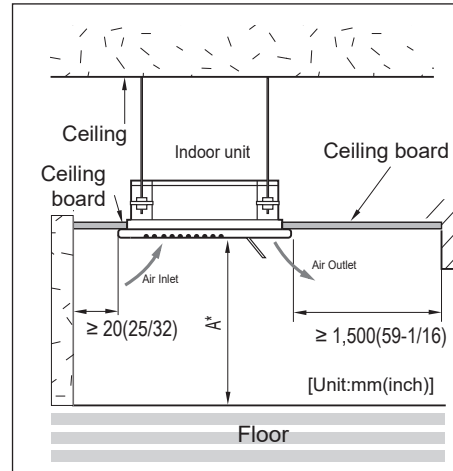
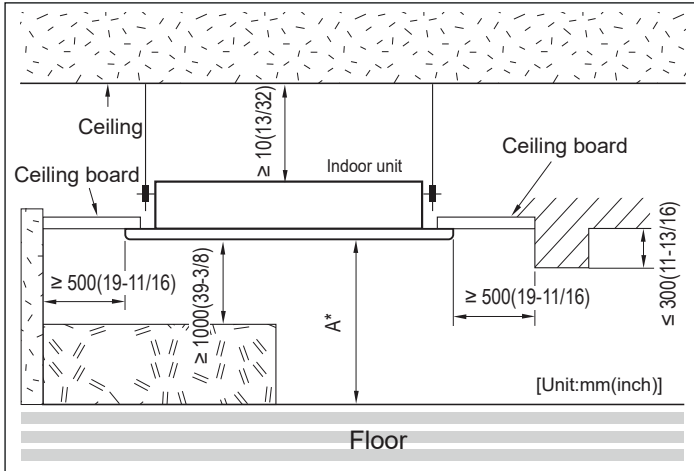

Notes

1. * : A, Installation Height from the floor

Type	Installation Height (A)		
	Min.	Standard **	Max.
Ceiling Mounted Cassette 1Way	1.8 m (5.91 ft)	2.7 m (8.86 ft)	3.3 m (9.84 ft)

** : Standard Height (Recommended)

If it exceeds the standard height, set the 'High Ceiling Mode'.

For details about function setting, refer to the installation manual.

< Cautions for Panel installation >

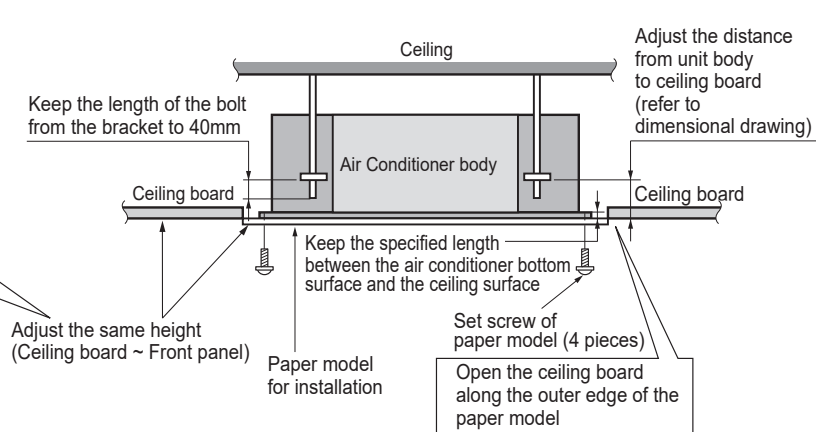
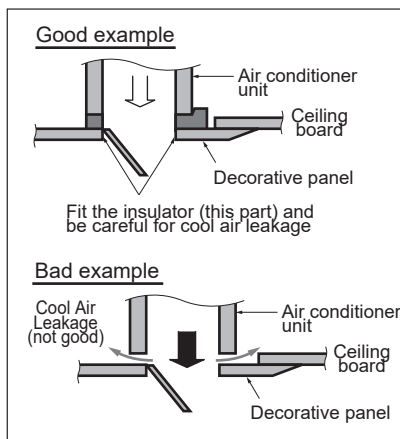

Note

- Places where products are installed should not be any obstacles to the air circulation or installation. Ensure the spaces from the wall, ceiling, or other obstacles.
- According to type of indoor unit, external appearance or installed structure could be different.
- According to product type, model line up, sales region..etc, applicability of each chassis could be different.
- Install certainly the decoration panel. Cool air leakage causes sweating or falling of water-drops.

2. ATNW24GTLP1

2.5 Piping Diagrams

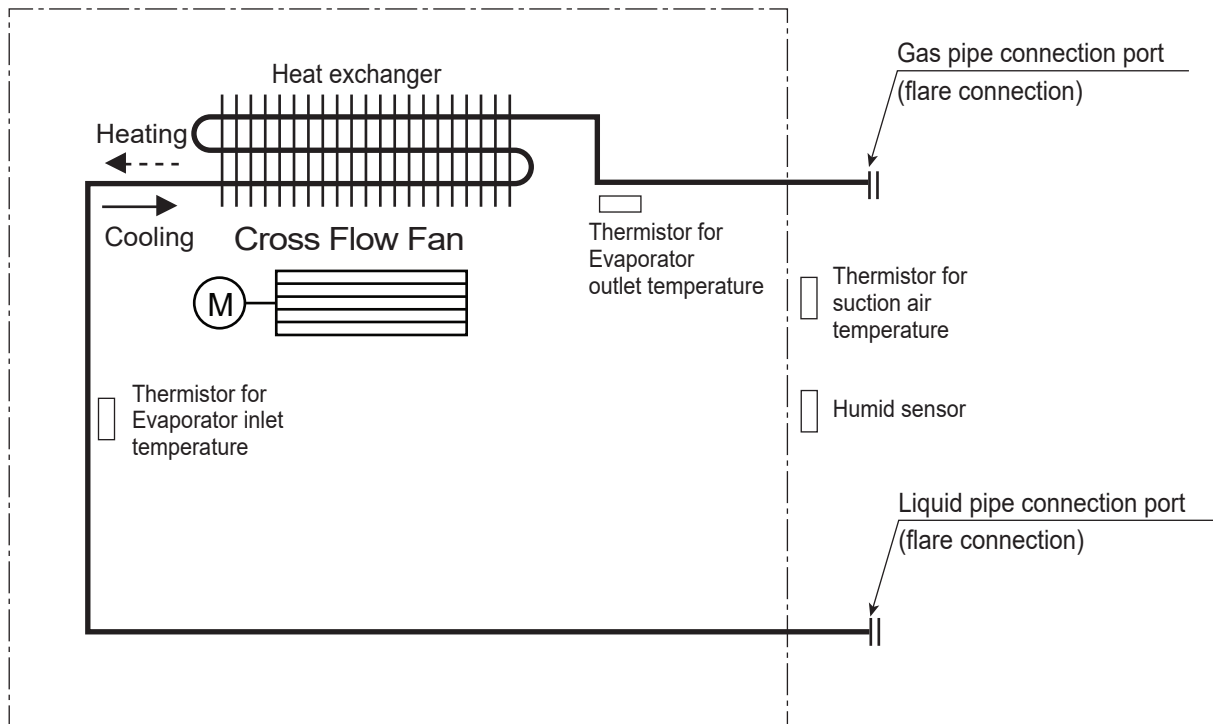

2. ATNW24GTL P1

2.6 Wiring Diagrams

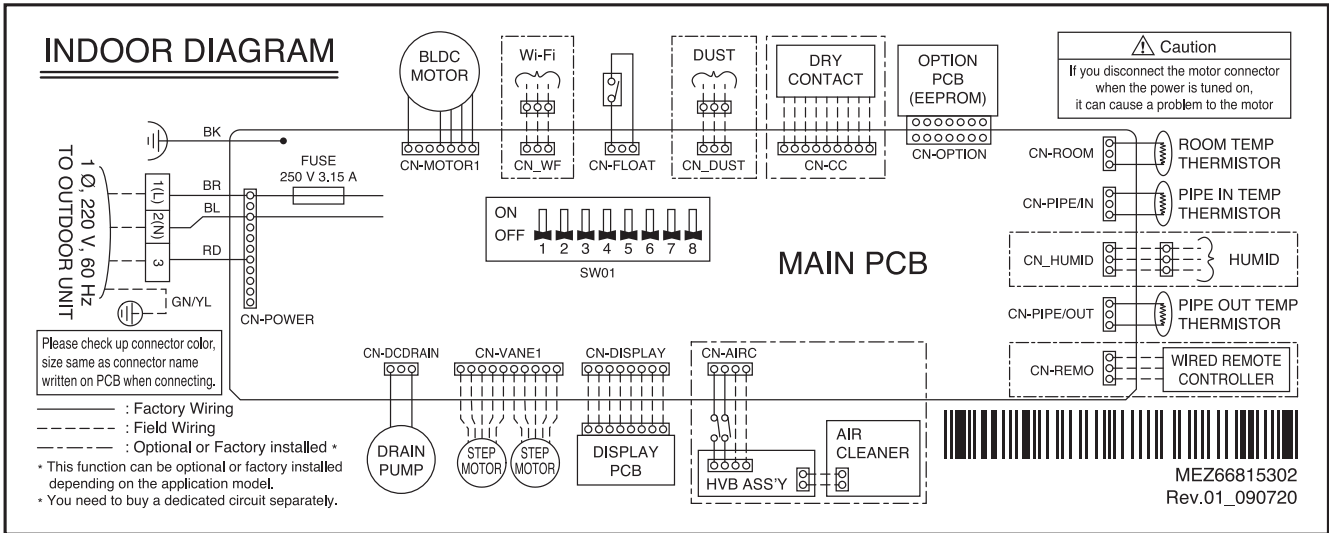

2. ATNW24GTLP1

2.7 Sound Levels

2.7.1 Pressure Levels

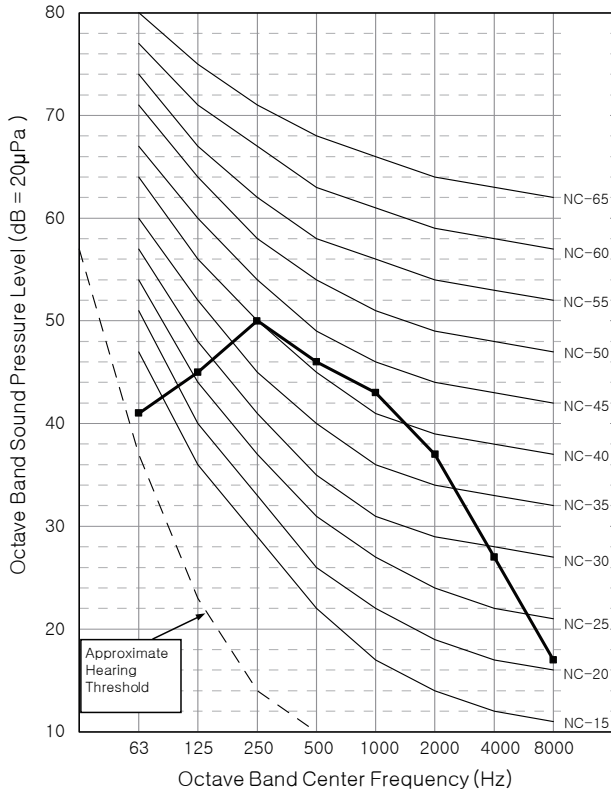

Sound level [dB(A), @ Standard condition]	
Cooling ((SH)/H/M/L)	- / 46.0 / 43.0 / 40.0
Heating ((SH)/H/M/L)	- / 46.0 / 43.0 / 40.0

Note

- Sound measured at some distance away from the center of the unit.
- Data is valid at free field condition.
- Reference acoustic pressure 0dB = 20µPa.
- Data is valid at nominal operation condition.
Refer to the Model Specifications for nominal conditions(Power source and Ambient temperature, etc)
- Sound levels can be increased in accordance with installation and operating conditions.
(Static pressure mode, used air guide, Room target temperature setting, etc)
- Sound pressure level is measured on the rated condition in the anechoic rooms by ISO 3745 standard.
Therefore, these values can be increased owing to ambient conditions during operation.

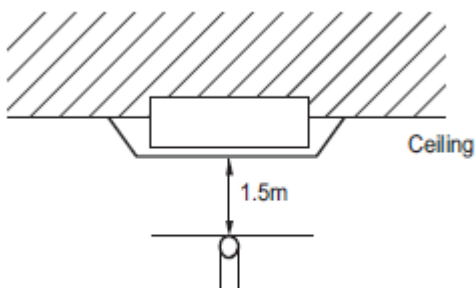

* Measuring place : Anechoic chamber

2. ATNW24GTLP1

2.8 Air flow and temperature distributions

2.8.1 Cooling operation

Discharge angle: 50°

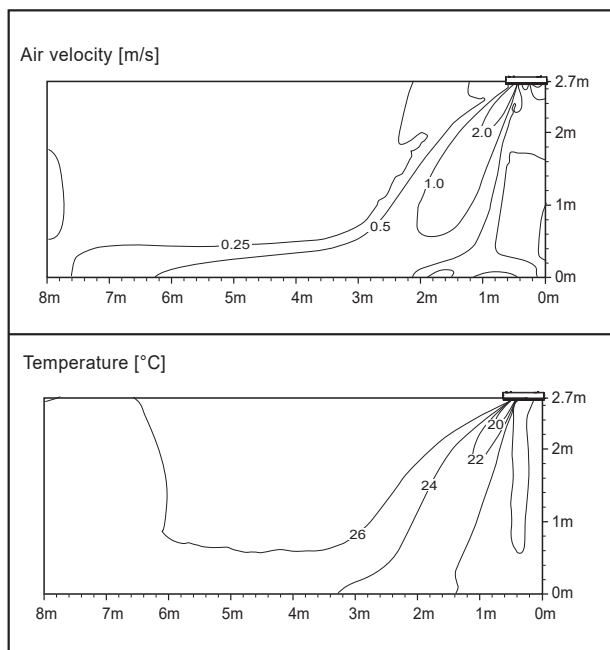

Note

- These figures are accordance with normal certain condition and environment.
(Airflow step is 'High', Air discharge angle is fixed as indicated angle.)
- Indoor airflow distribution under actual installation or operating conditions depends on ambient temperature, ceiling height, product installation direction / location, indoor / Heating load, and other obstacles, etc.

2. ATNW24GTLP1

2.8.2 Heating operation

Discharge angle: 60°

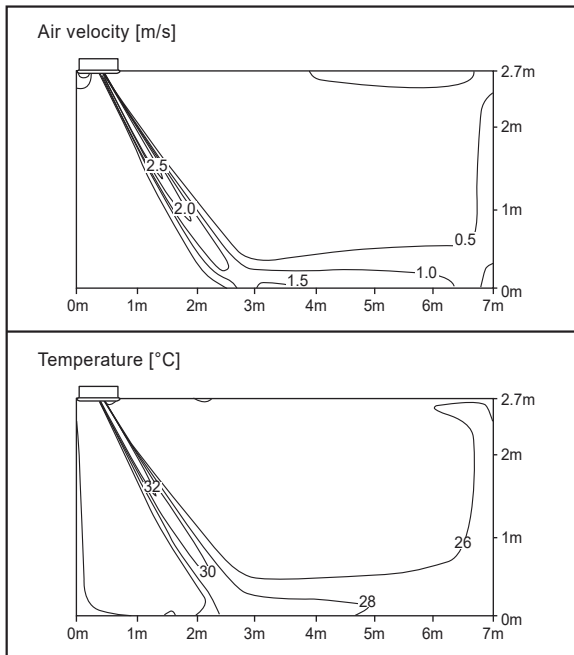

Note

- These figures are accordance with normal certain condition and environment.
(Airflow step is 'High', Air discharge angle is fixed as indicated angle.)
- Indoor airflow distribution under actual installation or operating conditions depends on ambient temperature, ceiling height, product installation direction / location, indoor / Heating load, and other obstacles, etc.

1. ATNW18GPLP1

1.1 Specifications

Category		Unit	Specification
Major	Minor		
Classification	Chassis	-	TP
Power Supply	Case 1	-	220, 1, 60
	Case 2	-	-
	Limit Range of Voltage(Case 1)	V	198~242
	Limit Range of Voltage(Case 2)	V	-
Cooling Capacity	Nominal	kW	5.28
		Btu/h	18,000
Heating Capacity	Nominal	kW	5.28
		Btu/h	18,000
Power Input(Indoor)	H/M/L	W	-
Running Current	H/M/L	A	-
Indoor Fan	Type	-	2D Turbo
	Quantity	EA	1
	Air Flow Rate((SH)/H/M/L)	m ³ /min	- / 16.5 / 14.5 / 13.0
	Air Flow Rate Range(Min~Max)	m ³ /min	13.0~16.5
	External Static Pressure_Factory Set	Pa	-
Indoor Fan Motor	Type	-	BLDC
	Drive	-	-
	Output	W	50.3
		No.	1
Dehumidification Rate	-	ℓ/h	1.30
Heat Exchanger	Rows x Columns x FPI	-	2 x 8 x 19
	No.	-	1
	Fin Type	-	Louver
	Face Area	m ²	0.35
Dimensions	Net(W x H x D)	mm	840 x 204 x 840
	Shipping(W x H x D)	mm	922 x 276 x 917
Weight	Net	kg	21.5
	Shipping	kg	26.0
Exterior	Color	-	Morning Fog
	RAL (Classic)	-	RAL 9001
Air Filter	Type	-	Long Life
Protection Device	Fuse	-	O
	Overload Protector for Fan Motor	-	Thermal Protector for Fan Motor
Refrigerant	Type	-	R410A
	Control Type	-	-
Drain Pipe(Natural Drainage)	O.D / I.D	mm(inch)	-
Drain Pipe(using Drain Pump)	O.D / I.D	mm(inch)	32.0 / 25.0
Pipe Connecting Socket	Liquid	mm(inch)	Φ6.35 (1/4)
	Gas	mm(inch)	Φ12.7 (1/2)
	Connection Type(Liquid)	-	Flare
	Connection Type(Gas)	-	Flare
Sound Pressure Level(Indoor Unit)	Cooling ((SH)/H/M/L)	dB(A)	- / 36.0 / 34.0 / 32.0
	Heating ((SH)/H/M/L)	dB(A)	- / 36.0 / 34.0 / 32.0
Measurement Standard (Pressure Level)	-	-	ISO 3745
Sound Power Level(Indoor Unit)	Cooling ((SH)/H/M/L)	dB(A)	-
	Heating ((SH)/H/M/L)	dB(A)	-
Measurement Standard (Power Level)	-	-	-
Connecting Cable	Power and Communication cable(H07RN-F)	mm ² × cores	0.75 x 4

1. ATNW18GPLP1

Category		Unit	Specification
Major	Minor		
Power Supply Type to Indoor	-	-	-
Electrical Characteristic	Maximum Fuse Amperes (MFA)	A	15
	Indoor Fan Motor_Full Load Amperes (FLA / Max)	A	0.6

Note

- Due to our policy of innovation some specifications may be changed without notification.
- Wiring cable size must comply with the applicable local and national code.
And "Electric characteristics" should be considered for electrical work and design.
- Especially the power cable and circuit breaker should be selected in accordance with that.
- Sound Level Values are measured at Noise Measuring chamber accordance with standard.
Therefore, these values depend on the ambient conditions and values are normally higher in actual operation.

1. ATNW18GPLP1

1.2 List of Functions

Category	Functions	Availability
Air Flow	Air Supply Outlet	4
	Airflow Direction Control (left & right)	X
	Airflow Direction Control (up & down)	Auto
	Auto Swing (left & right)	X
	Auto Swing (up & down)	O
	Airflow Steps (fan/cool/heat)	4 / 5 / 4
	Fan Speed Auto*	X
	Power Cool/Heat	O / X
	Swirl Wind*	O
	Refresh Mode**	X
	Smart Mode**	X
	Indirect Wind*	O
	Direct Wind*	O
	Dry Operation	O
Air Purification	Air Purify	Accessory
	Ionizer	X
	UV-C	X
	Allergy Filter	X
	Pre-Filter	O
	PM1.0 Filter	X
Reliability	Hot Start	O
	Self Diagnosis	O
Convenience	Auto Mode	O
	Auto Dry Operation**	X
	Auto Restart	O
	Child Lock*	O
	Forced Operation	O
	Group Control*	O
	Sleep Timer**	O
	Turn On/Off Reservation**	O
	Schedule**	O
	Two Thermistor Control*	O
	Time Limit Control (Energy saving)***	O
External On/Off	O	
Installation	Drain Pump	O
	High Ceiling Operation*	O
Special Functions	Wi-Fi Control	Accessory
	Comfort Cooling (Humidity Control)***	O
	Auto Elevation Grille	Accessory(PTEGM0)
	Human Detection Function***	Accessory
	Floor Detection Function***	X

Note

- O : Applied, X : Not Applied, - : Unconfirmed or irrelevant
- Embedded : A kit is provided by default for using this function when the product is manufactured.
- Accessory : Ordered and purchased separately the accessory package referring to the model name provided and install at field.
- Accessory line-ups varies by region, so check your local catalogue or local sales material.
- Some functions can be limited by remote controller.
- In case of cassette type indoor units, Plasma kit and Auto Elevation Grille functions are not applicable at the same time.
- 'Auto Mode' varies depending on the outdoor unit type.
 - Auto Change Over(Single Heat Pump Outdoor Unit)
 - Auto Mode Select(Multi Heat Pump Outdoor Unit)

1. ATNW18GPLP1

- Auto Intensity Control(Cooling Only Outdoor Unit)
- * : These functions need to connect the wired remote controller.
- ** : This functions need to connect to the Standard II / III wired remote controller.
- *** : This functions need to connect to the Standard III wired remote controller.

1. ATNW18GPLP1

1.3 Accessory Compatibility List

Category	Accessory Name	Model Name	Description	Compatibility
Remote Controller	Wired - Premium	PREMTA000	-	O
		PREMTA000A	-	O
		PREMTA000B	-	O
	Wired - RS3 (Standard III)	PREMTB100	White	O
		PREMTBB10	Black	O
	Wired - RS2 (Standard II)	PREMTB001	White	O
		PREMTBB01	Black	O
	Wired - Simple	PQRCVCL0QW	White	O
		PQRCVCL0Q	Black	O
	Wired - Simple for hotel	PQRCHCA0QW	White	O
		PQRCHCA0Q	Black	O
	Wireless	PQWRQC0FDB	For Cooling only	X
		PQWRHQ0FDB	For Heat pump	O
		PWLSSB21C	For Cooling only	X
PWLSSB21H		For Heat pump	O	
Dry Contact	Simple	PDRYCB000	1 input port, AC 220 - 240V	O
		PDRYCB100	1 input port, AC 24V	O
	Communication	PDRYCB400	2 input port	O
		PDRYCB300	8 input port, For 3rd party Thermostat	O
		PDRYCB320	8 input port, For 3rd Party Thermostat (Analog Input)	O
PDRYCB500	For 3rd Party Controller(Modbus RTU)	O		
Integration Device	Remote Temperature sensor	PQRSTA0	-	O
	Group Control wire	PZCWRCG3	Cable Assembly for group control (Y-type cable : 0.25m, cable : 9.6m)	O
ETC	Extension wire	PZCWRC1	Extension wire for IDU-wired remote controller (9.6m)	O
	2-Remo Control wire	PZCWRC2	-	X
	Wi-Fi Modem	PWFMD200	-	O
	Wi-Fi Extension cable	PWYREW000	USB Extension cable : 10 m	O
	Independent Power Module	PRIP0	For Multi V Indoor Unit	X
	Multi-tenant Power module	PINPMB001	For Multi V Indoor Unit	X
	Refrigerant Leakage Detector	PRLDNVS0	For Multi V Indoor Unit (R410A)	X
	Human Detection Sensor	PTVSMA0	For Cassette 4-way	O
		PTVSAA0	For Cassette Dual Vane 4-way	X
	Floor Detection Sensor	PTFSMA0	For Cassette Dual Vane 4-way	X
	Auto Elevation Grille	PTEGM0	For Cassette 4-way	X
	Air Purification Kit	PTAHTP0	For Cassette 1-way	X
		PTAHMP0	For Cassette 4-way	O
		PTAHYP0	For Cassette Round	X
	EEV Kit	PRGK024A0	For Multi V Indoor Unit	X
	Auxiliary Heater Relay Kit	PRARS1	For Wall Mounted / Art Cool Indoor Units	X
		PRARH1	For Cassette / Duct Indoor Units	X
	Ventilation Kit	PTVK430	For TR/TQ/TP/TN/TM Chassis	X
		PTVK410 / PTVK420	For TP/TN/TM Chassis	X
	Cassette Cover	PTDCQ	For TR/TQ Chassis	X
PTDCM		For TP/TN/TM Chassis	X	
PTDCA		For TM-A/TP-B Chassis	X	

Note

- O: Possible, X: Impossible, -: Unconfirmed or irrelevant.
- *: Some advanced functions controlled by individual controller cannot be operated.
- Air Purification Kit and Auto Elevation Grille are not applicable at the same time.
- If there is a difference in development time between the product and the remote controller, some functions cannot be operated.
- If you need more detail, please refer to the Control(BECON) PDB or the manual of product.
(<http://partner.lge.com/global> : Home> Doc.Library> Product > Control(BECON)).

1. ATNW18GPLP1

1.4 Dimensions

1.4.1 Product

[Unit: mm]
 Chassis Code : TP
 DWG No. : TBA36388101_rev01

3D VIEW

VIEW A
Fresh Air Intake Hole

Installation position of body
 (Keep this distance between the bottom surface of the body and ceiling surface)

Installation position of body

No.	Part Name	Description
11	Fresh Air intake hole	Knock-out type
10	Flexible Drain Hose	Supplied with product
9	Decoration Corner Cover	Supplied with pane
8	Decoration Panel (Accessory)	PT-M*HWO
7	Air Outlet	-
6	Air Inlet	-
5	Wired remote controller wire routing hole	-
4	Power and communication cable routing hole	-
3	Drain Pipe Connection	-
2	Liquid Pipe Connection	-
1	Gas Pipe Connection	-

Symbols

- View Direction
- Datum line
- Refrigerant/Drain Piping Direction

Note

- Unit should be installed in compliance with the local regulations or applicable national codes.
- Unit should be grounded in accordance with the local regulations or applicable national codes.
- All electrical components and materials to be supplied from the site must comply with the local regulations or international codes.

1. ATNW18GPLP1

1.4.2 Install Space

< Minimum Installation Space >

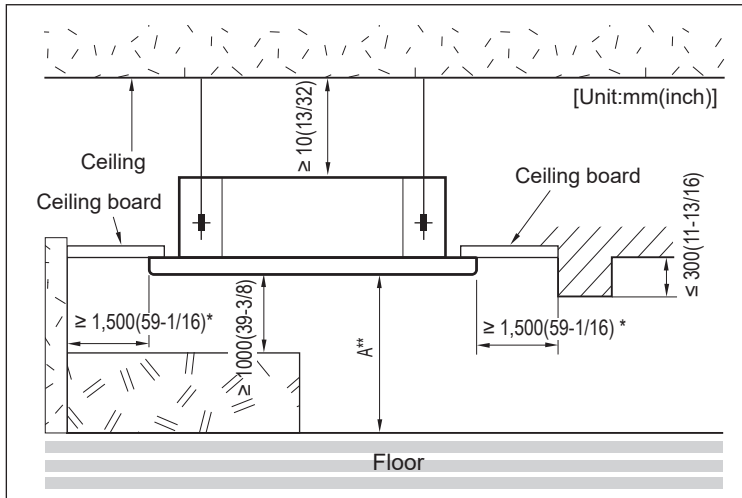

Notes

1. *: Minimum Installation Space to Air flow direction
A separation distance of at least 1,500 mm is required throughout the airflow direction.

2. **: A, Installation Height from the floor

Capacity Class	Installation Height (A)		
	Min.	Standard ***	Max.
< 10 kW	2.0 m (6.56 ft)	2.7 m (8.86 ft)	3.6 m (11.81 ft)
≥ 10 kW	2.5 m (8.20 ft)	3.2 m (10.50 ft)	4.2 m (13.78 ft)

*** : Standard Height (Recommended)

If it exceeds the standard height, set the 'High Ceiling Mode'.

For details about function setting, refer to the installation manual.

< Cautions for Panel installation >

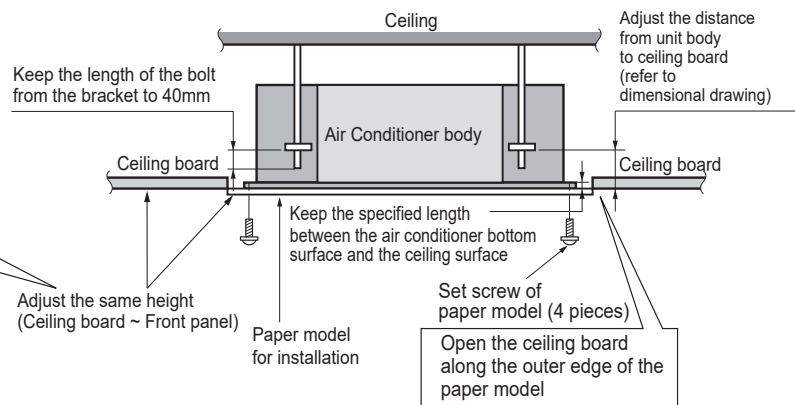
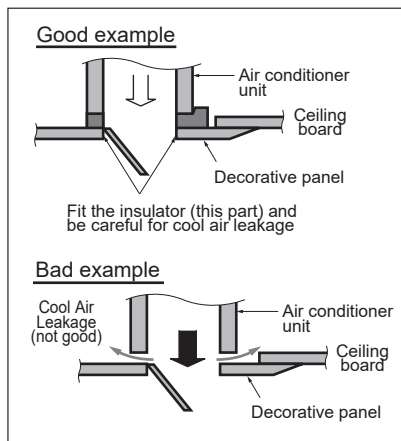

< Series installation >

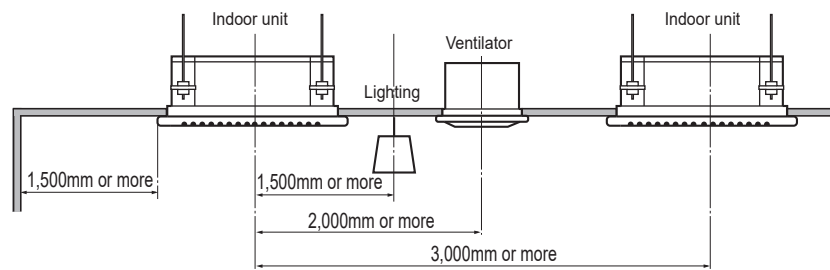

※ According to type of indoor unit, external appearance could be different.

Note

- Places where products are installed should not be any obstacles to the air circulation or installation. Ensure the spaces from the wall, ceiling, or other obstacles.
- According to type of indoor unit, external appearance or installed structure could be different.
- According to product type, model line up, sales region..etc, applicability of each chassis could be different.
- Install certainly the decoration panel. Cool air leakage causes sweating or falling of water-drops.

1. ATNW18GPLP1

1.5 Piping Diagrams

1.5.1 Normal

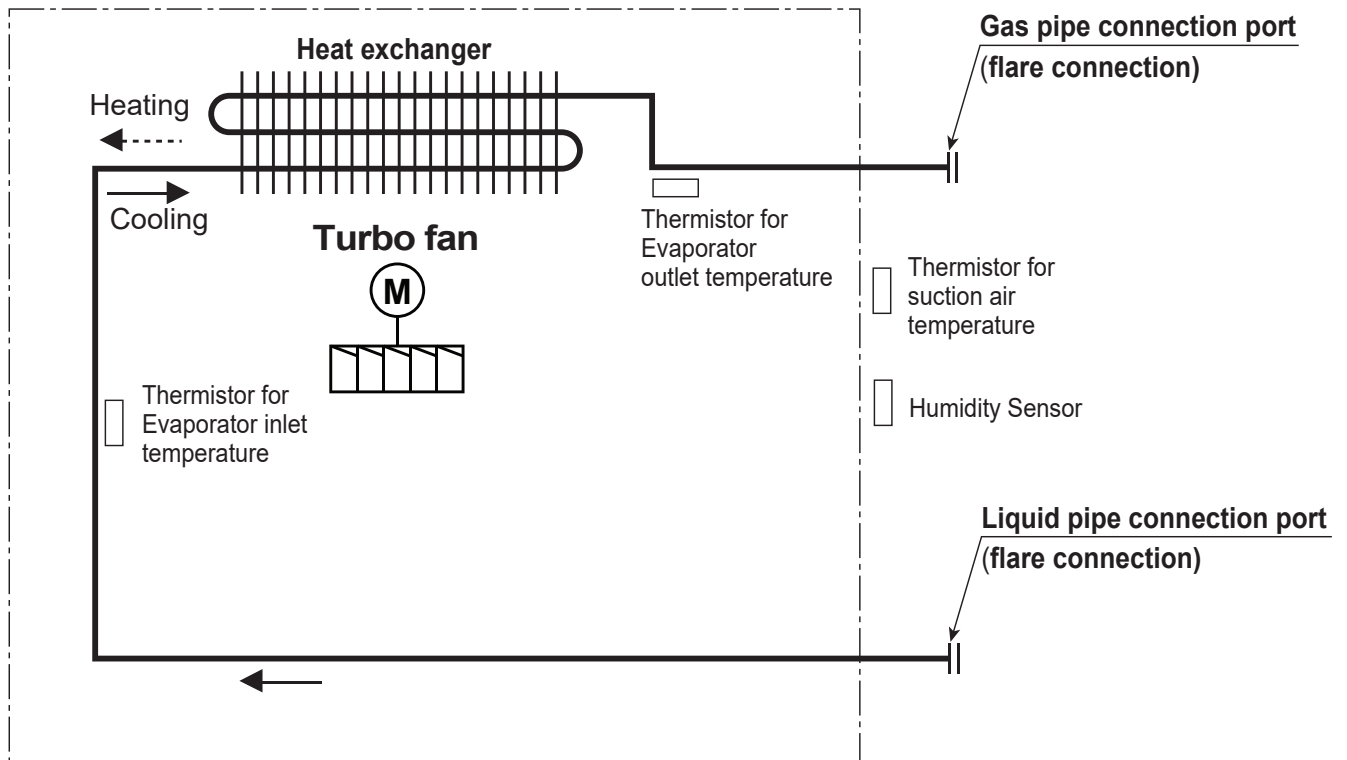

1. ATNW18GPLP1

1.6 Wiring Diagrams

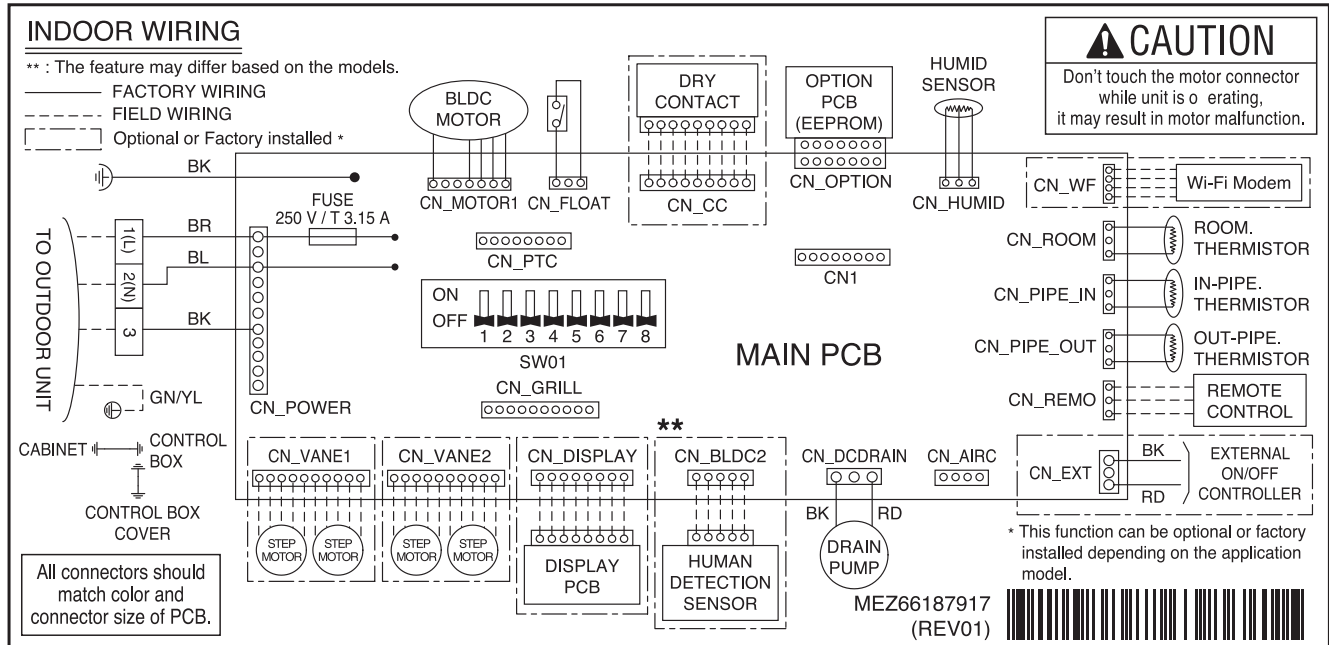

1. ATNW18GPLP1

1.7 Sound Levels

1.7.1 Pressure Levels

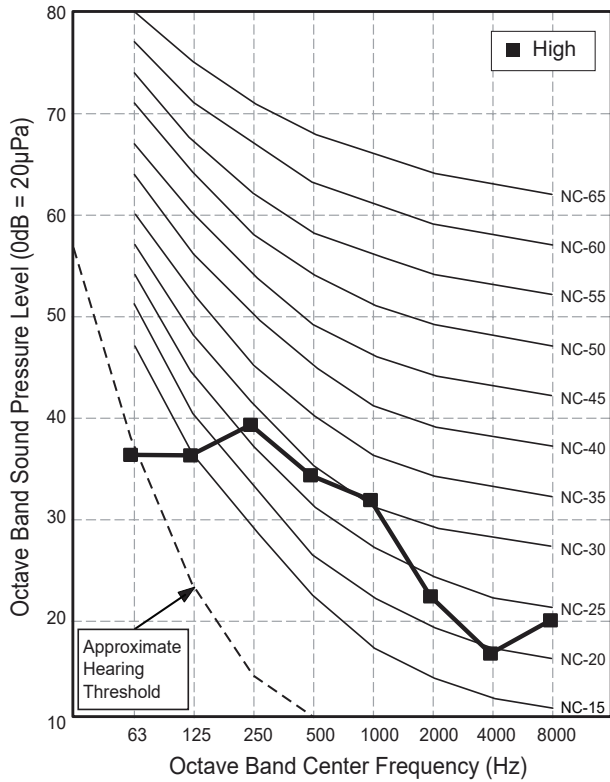

Sound level [dB(A), @ Standard condition]	
Cooling ((SH)/H/M/L)	- / 36.0 / 34.0 / 32.0
Heating ((SH)/H/M/L)	- / 36.0 / 34.0 / 32.0

Note

- Sound measured at some distance away from the center of the unit.
- Data is valid at free field condition.
- Reference acoustic pressure 0dB = 20µPa.
- Data is valid at nominal operation condition.
Refer to the Model Specifications for nominal conditions(Power source and Ambient temperature, etc)
- Sound levels can be increased in accordance with installation and operating conditions.
(Static pressure mode, used air guide, Room target temperature setting, etc)
- Sound pressure level is measured on the rated condition in the anechoic rooms by ISO 3745 standard.
Therefore, these values can be increased owing to ambient conditions during operation.

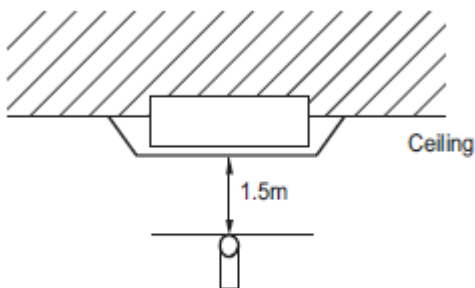

* Measuring place : Anechoic chamber

1. ATNW18GPLP1

1.8 Air flow and temperature distributions

1.8.1 Cooling

Discharge angle: 40°

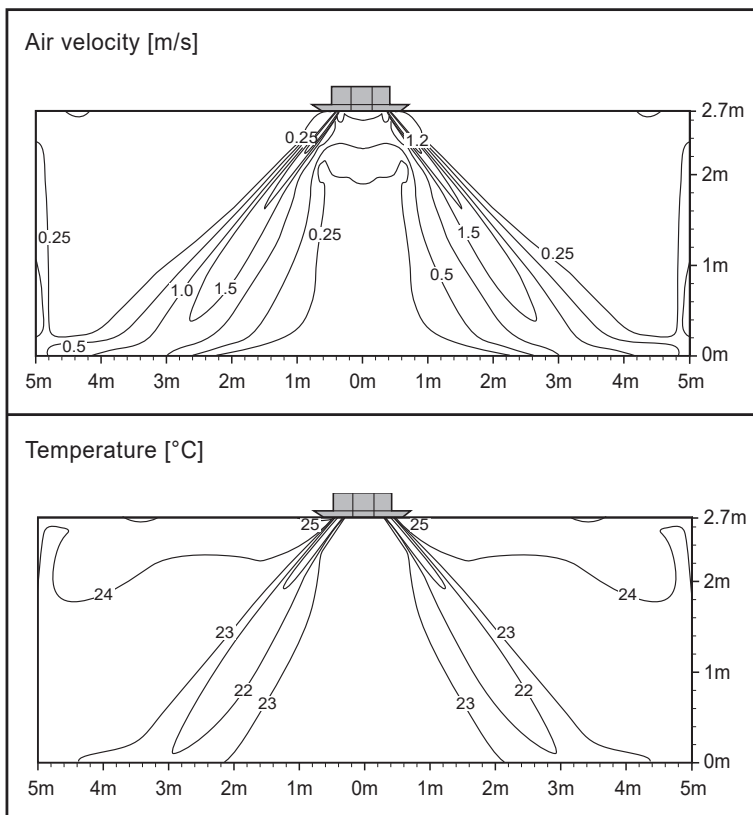

Note

- These figures are accordance with normal certain condition and environment.
(Airflow step is 'High', Air discharge angle is fixed as indicated angle.)
- Indoor airflow distribution under actual installation or operating conditions depends on ambient temperature, ceiling height, product installation direction / location, indoor / Heating load, and other obstacles, etc.

1. ATNW18GPLP1

1.8.2 Heating

Discharge angle: 50°

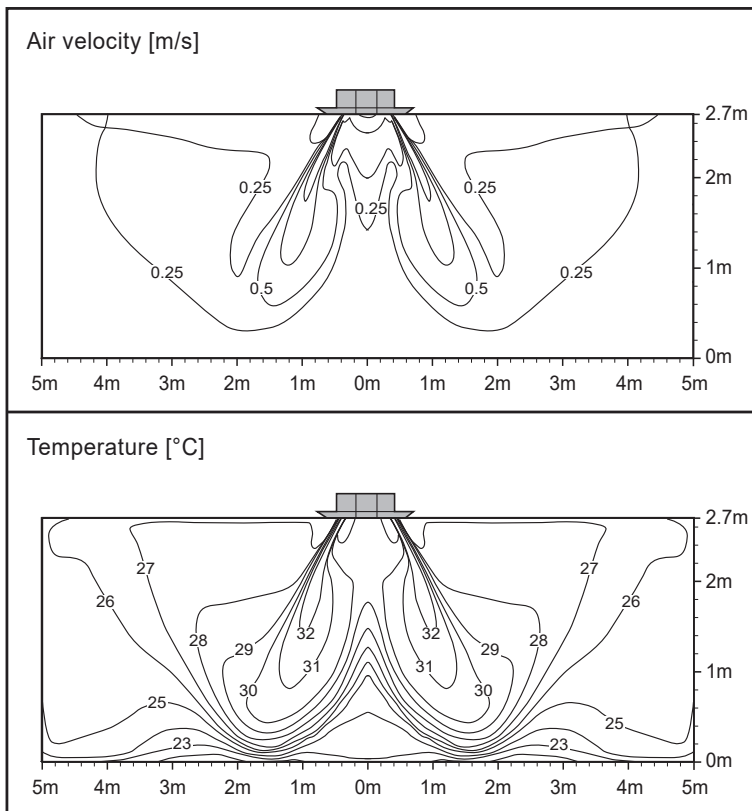

Note

- These figures are accordance with normal certain condition and environment.
(Airflow step is 'High', Air discharge angle is fixed as indicated angle.)
- Indoor airflow distribution under actual installation or operating conditions depends on ambient temperature, ceiling height, product installation direction / location, indoor / Heating load, and other obstacles, etc.

2. ATNW24GPLP1

2.1 Specifications

Category		Unit	Specification
Major	Minor		
Classification	Chassis	-	TP
Power Supply	Case 1	-	220, 1, 60
	Case 2	-	-
	Limit Range of Voltage(Case 1)	V	198~242
	Limit Range of Voltage(Case 2)	V	-
Cooling Capacity	Nominal	kW	7.03
		Btu/h	24,000
Heating Capacity	Nominal	kW	7.62
		Btu/h	26,000
Power Input(Indoor)	H/M/L	W	-
Running Current	H/M/L	A	-
Indoor Fan	Type	-	2D Turbo
	Quantity	EA	1
	Air Flow Rate((SH)/H/M/L)	m ³ /min	- / 17.0 / 15.0 / 13.0
	Air Flow Rate Range(Min~Max)	m ³ /min	13.0~17.0
	External Static Pressure_Factory Set	Pa	-
Indoor Fan Motor	Type	-	BLDC
	Drive	-	-
	Output	W	50.3
		No.	1
Dehumidification Rate	-	ℓ/h	2.40
Heat Exchanger	Rows x Columns x FPI	-	2 x 8 x 19
	No.	-	1
	Fin Type	-	Louver
	Face Area	m ²	0.35
Dimensions	Net(W x H x D)	mm	840 x 204 x 840
	Shipping(W x H x D)	mm	922 x 276 x 917
Weight	Net	kg	21.5
	Shipping	kg	26.0
Exterior	Color	-	Mornig Fog
	RAL (Classic)	-	RAL 9001
Air Filter	Type	-	Long Life
Protection Device	Fuse	-	O
	Overload Protector for Fan Motor	-	Thermal Protector for Fan Motor
Refrigerant	Type	-	R410A
	Control Type	-	-
Drain Pipe(Natural Drainage)	O.D / I.D	mm(inch)	-
Drain Pipe(using Drain Pump)	O.D / I.D	mm(inch)	32.0 / 25.0
Pipe Connecting Socket	Liquid	mm(inch)	Φ9.52 (3/8)
	Gas	mm(inch)	Φ15.88 (5/8)
	Connection Type(Liquid)	-	Flare
	Connection Type(Gas)	-	Flare
Sound Pressure Level(Indoor Unit)	Cooling ((SH)/H/M/L)	dB(A)	- / 38.0 / 36.0 / 34.0
	Heating ((SH)/H/M/L)	dB(A)	- / 38.0 / 36.0 / 34.0
Measurement Standard (Pressure Level)	-	-	ISO 3745
Sound Power Level(Indoor Unit)	Cooling ((SH)/H/M/L)	dB(A)	-
	Heating ((SH)/H/M/L)	dB(A)	-
Measurement Standard (Power Level)	-	-	-
Connecting Cable	Power and Communication cable(H07RN-F)	mm ² × cores	0.75 x 4

2. ATNW24GPLP1

Category		Unit	Specification
Major	Minor		
Power Supply Type to Indoor	-	-	-
Electrical Characteristic	Maximum Fuse Amperes (MFA)	A	25
	Indoor Fan Motor_Full Load Amperes (FLA / Max)	A	0.6

Note

- Due to our policy of innovation some specifications may be changed without notification.
- Wiring cable size must comply with the applicable local and national code.
And "Electric characteristics" should be considered for electrical work and design.
- Especially the power cable and circuit breaker should be selected in accordance with that.
- Sound Level Values are measured at Noise Measuring chamber accordance with standard.
Therefore, these values depend on the ambient conditions and values are normally higher in actual operation.

2. ATNW24GPLP1

2.2 List of Functions

Category	Functions	Availability
Air Flow	Air Supply Outlet	4
	Airflow Direction Control (left & right)	X
	Airflow Direction Control (up & down)	Auto
	Auto Swing (left & right)	X
	Auto Swing (up & down)	O
	Airflow Steps (fan/cool/heat)	4 / 5 / 4
	Fan Speed Auto*	X
	Power Cool/Heat	O / X
	Swirl Wind*	O
	Refresh Mode**	X
	Smart Mode**	X
	Indirect Wind*	O
	Direct Wind*	O
	Dry Operation	O
Air Purification	Air Purify	Accessory
	Ionizer	X
	UV-C	X
	Allergy Filter	X
	Pre-Filter	O
	PM1.0 Filter	X
Reliability	Hot Start	O
	Self Diagnosis	O
Convenience	Auto Mode	O
	Auto Dry Operation**	X
	Auto Restart	O
	Child Lock*	O
	Forced Operation	O
	Group Control*	O
	Sleep Timer**	O
	Turn On/Off Reservation**	O
	Schedule**	O
	Two Thermistor Control*	O
	Time Limit Control (Energy saving)***	O
External On/Off	O	
Installation	Drain Pump	O
	High Ceiling Operation*	O
Special Functions	Wi-Fi Control	Accessory
	Comfort Cooling (Humidity Control)***	O
	Auto Elevation Grille	Accessory(PTEGM0)
	Human Detection Function***	Accessory
	Floor Detection Function***	X

Note

- O : Applied, X : Not Applied, - : Unconfirmed or irrelevant
- Embedded : A kit is provided by default for using this function when the product is manufactured.
- Accessory : Ordered and purchased separately the accessory package referring to the model name provided and install at field.
- Accessory line-ups varies by region, so check your local catalogue or local sales material.
- Some functions can be limited by remote controller.
- In case of cassette type indoor units, Plasma kit and Auto Elevation Grille functions are not applicable at the same time.
- 'Auto Mode' varies depending on the outdoor unit type.
 - Auto Change Over(Single Heat Pump Outdoor Unit)
 - Auto Mode Select(Multi Heat Pump Outdoor Unit)

2. ATNW24GPLP1

- Auto Intensity Control(Cooling Only Outdoor Unit)
- * : These functions need to connect the wired remote controller.
- ** : This functions need to connect to the Standard II / III wired remote controller.
- *** : This functions need to connect to the Standard III wired remote controller.

2. ATNW24GPLP1

2.3 Accessory Compatibility List

Category	Accessory Name	Model Name	Description	Compatibility
Remote Controller	Wired - Premium	PREMTA000	-	O
		PREMTA000A	-	O
		PREMTA000B	-	O
	Wired - RS3 (Standard III)	PREMTB100	White	O
		PREMTBB10	Black	O
	Wired - RS2 (Standard II)	PREMTB001	White	O
		PREMTBB01	Black	O
	Wired - Simple	PQRCVCL0QW	White	O
		PQRCVCL0Q	Black	O
	Wired - Simple for hotel	PQRCHCA0QW	White	O
		PQRCHCA0Q	Black	O
	Wireless	PQWRQC0FDB	For Cooling only	X
		PQWRHQ0FDB	For Heat pump	O
		PWLSSB21C	For Cooling only	X
PWLSSB21H		For Heat pump	O	
Dry Contact	Simple	PDRYCB000	1 input port, AC 220 - 240V	O
		PDRYCB100	1 input port, AC 24V	O
	Communication	PDRYCB400	2 input port	O
		PDRYCB300	8 input port, For 3rd party Thermostat	O
		PDRYCB320	8 input port, For 3rd Party Thermostat (Analog Input)	O
PDRYCB500	For 3rd Party Controller(Modbus RTU)	O		
Integration Device	Remote Temperature sensor	PQRSTA0	-	O
	Group Control wire	PZCWRCG3	Cable Assembly for group control (Y-type cable : 0.25m, cable : 9.6m)	O
ETC	Extension wire	PZCWRC1	Extension wire for IDU-wired remote controller (9.6m)	O
	2-Remo Control wire	PZCWRC2	-	X
	Wi-Fi Modem	PWFMD200	-	O
	Wi-Fi Extension cable	PWYREW000	USB Extension cable : 10 m	O
	Independent Power Module	PRIP0	For Multi V Indoor Unit	X
	Multi-tenant Power module	PINPMB001	For Multi V Indoor Unit	X
	Refrigerant Leakage Detector	PRLDNVS0	For Multi V Indoor Unit (R410A)	X
	Human Detection Sensor	PTVSMA0	For Cassette 4-way	O
		PTVSAA0	For Cassette Dual Vane 4-way	X
	Floor Detection Sensor	PTFSMA0	For Cassette Dual Vane 4-way	X
	Auto Elevation Grille	PTEGM0	For Cassette 4-way	X
	Air Purification Kit	PTAHTP0	For Cassette 1-way	X
		PTAHMP0	For Cassette 4-way	O
		PTAHYP0	For Cassette Round	X
	EEV Kit	PRGK024A0	For Multi V Indoor Unit	X
	Auxiliary Heater Relay Kit	PRARS1	For Wall Mounted / Art Cool Indoor Units	X
		PRARH1	For Cassette / Duct Indoor Units	X
	Ventilation Kit	PTVK430	For TR/TQ/TP/TN/TM Chassis	X
		PTVK410 / PTVK420	For TP/TN/TM Chassis	X
	Cassette Cover	PTDCQ	For TR/TQ Chassis	X
PTDCM		For TP/TN/TM Chassis	X	
PTDCA		For TM-A/TP-B Chassis	X	

Note

- O: Possible, X: Impossible, -: Unconfirmed or irrelevant.
- *: Some advanced functions controlled by individual controller cannot be operated.
- Air Purification Kit and Auto Elevation Grille are not applicable at the same time.
- If there is a difference in development time between the product and the remote controller, some functions cannot be operated.
- If you need more detail, please refer to the Control(BECON) PDB or the manual of product.
(<http://partner.lge.com/global> : Home> Doc.Library> Product > Control(BECON)).

2. ATNW24GPLP1

2.4 Dimensions

2.4.1 Product

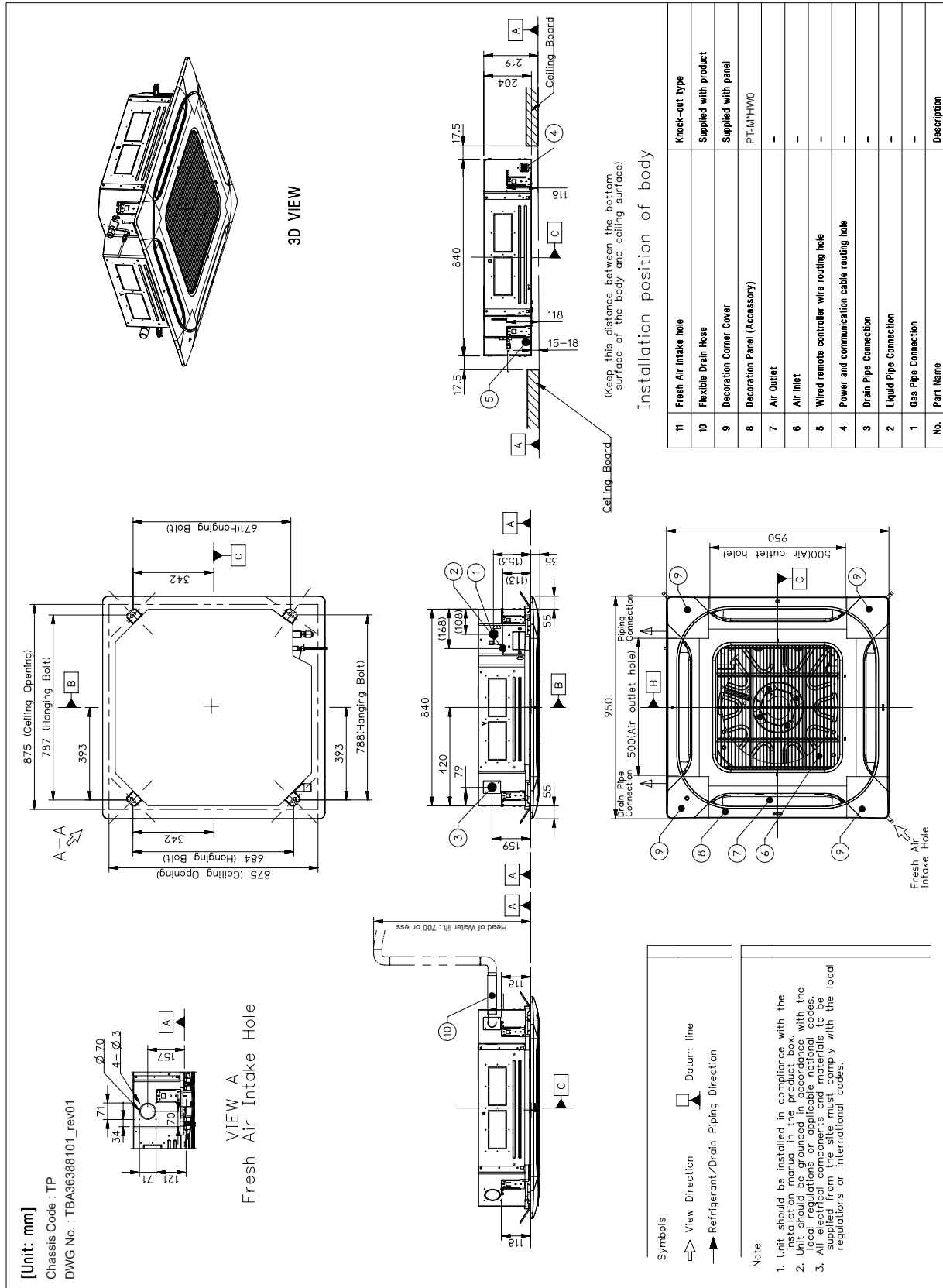

2. ATNW24GPLP1

2.4.2 Install Space

< Minimum Installation Space >

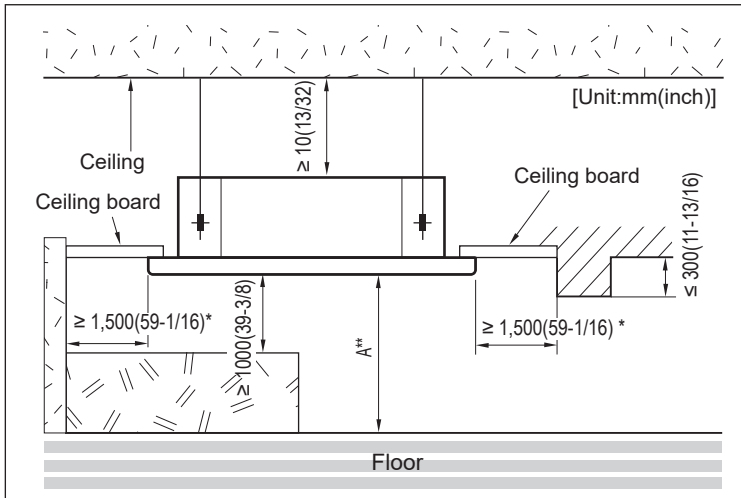

Notes

1. *: Minimum Installation Space to Air flow direction
A separation distance of at least 1,500 mm is required throughout the airflow direction.

2. **: A, Installation Height from the floor

Capacity Class	Installation Height (A)		
	Min.	Standard ***	Max.
< 10 kW	2.0 m (6.56 ft)	2.7 m (8.86 ft)	3.6 m (11.81 ft)
≥ 10 kW	2.5 m (8.20 ft)	3.2 m (10.50 ft)	4.2 m (13.78 ft)

*** : Standard Height (Recommended)

If it exceeds the standard height, set the 'High Ceiling Mode'.

For details about function setting, refer to the installation manual.

< Cautions for Panel installation >

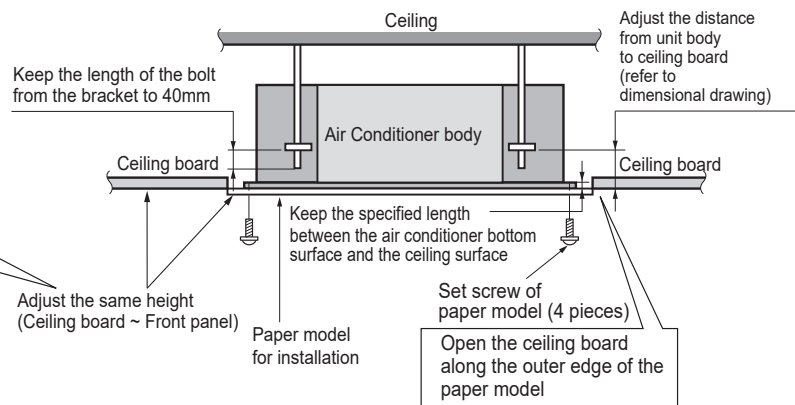
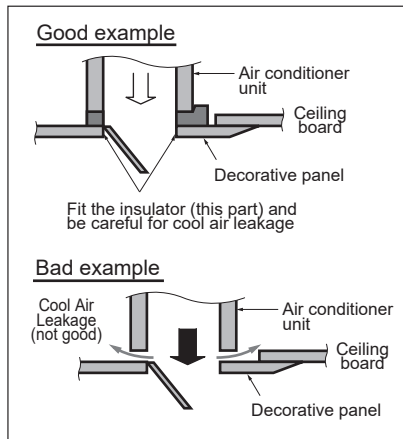

< Series installation >

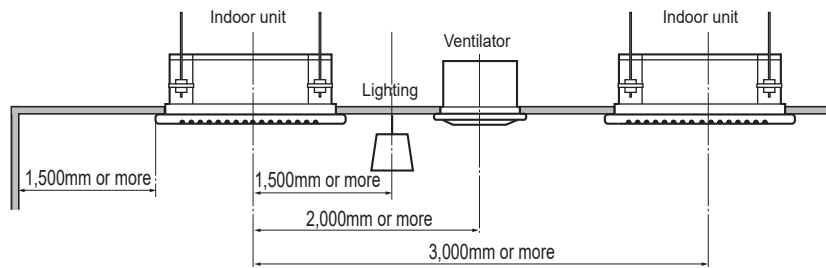

※ According to type of indoor unit, external appearance could be different.

Note

- Places where products are installed should not be any obstacles to the air circulation or installation. Ensure the spaces from the wall, ceiling, or other obstacles.
- According to type of indoor unit, external appearance or installed structure could be different.
- According to product type, model line up, sales region..etc, applicability of each chassis could be different.
- Install certainly the decoration panel. Cool air leakage causes sweating or falling of water-drops.

2. ATNW24GPLP1

2.5 Piping Diagrams

2.5.1 Normal

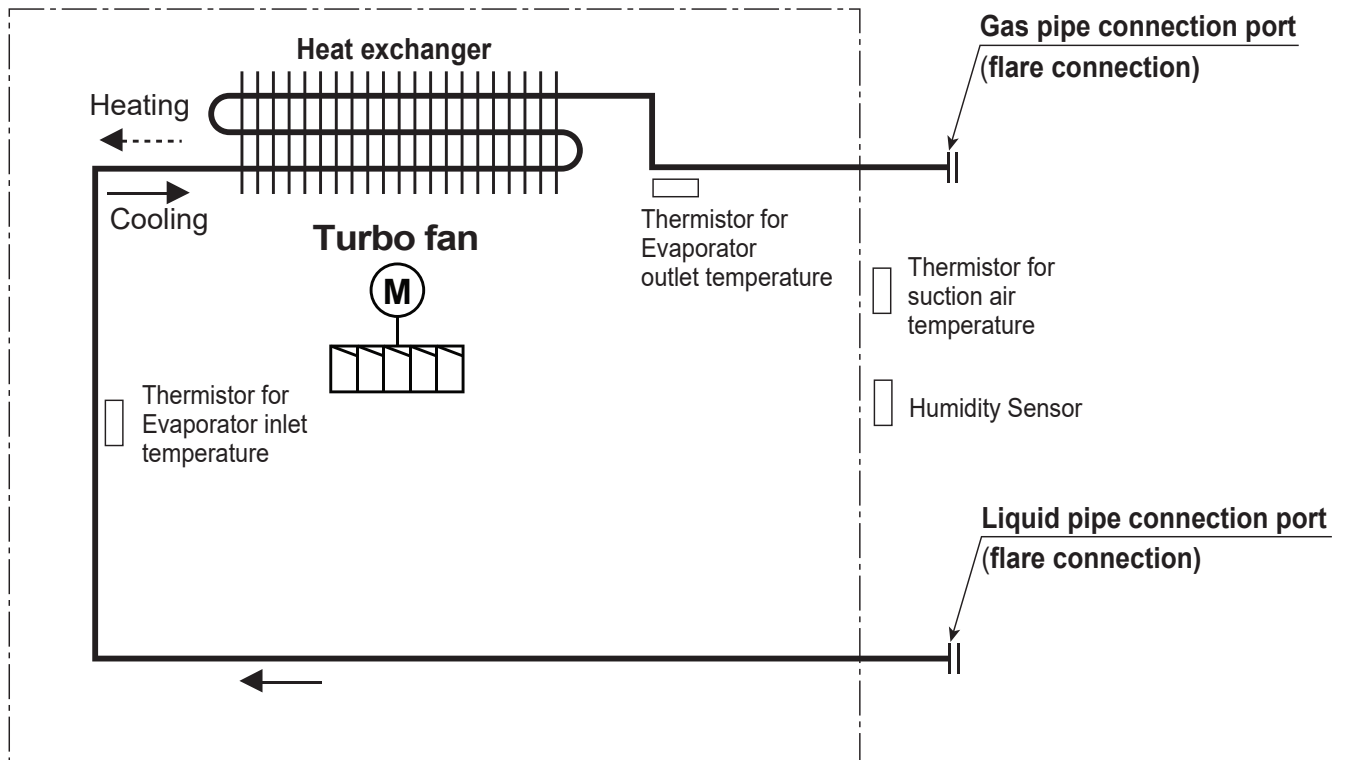

2. ATNW24GPLP1

2.6 Wiring Diagrams

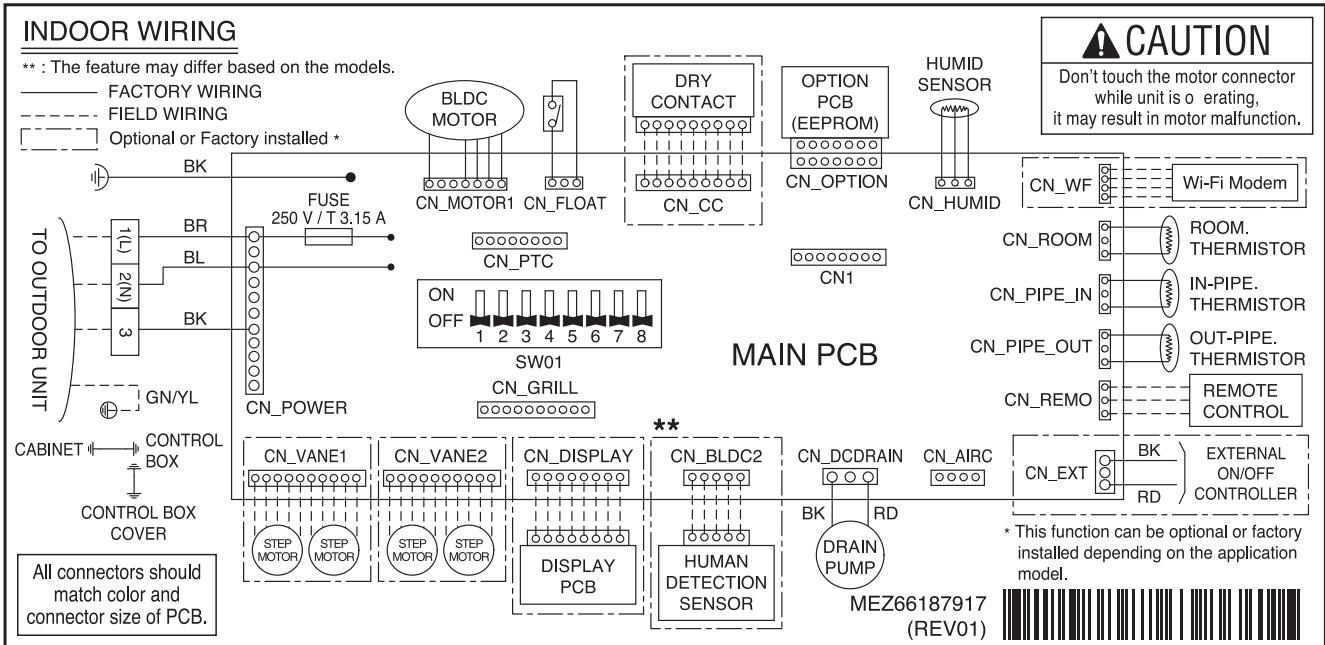

2. ATNW24GPLP1

2.7 Sound Levels

2.7.1 Pressure Levels

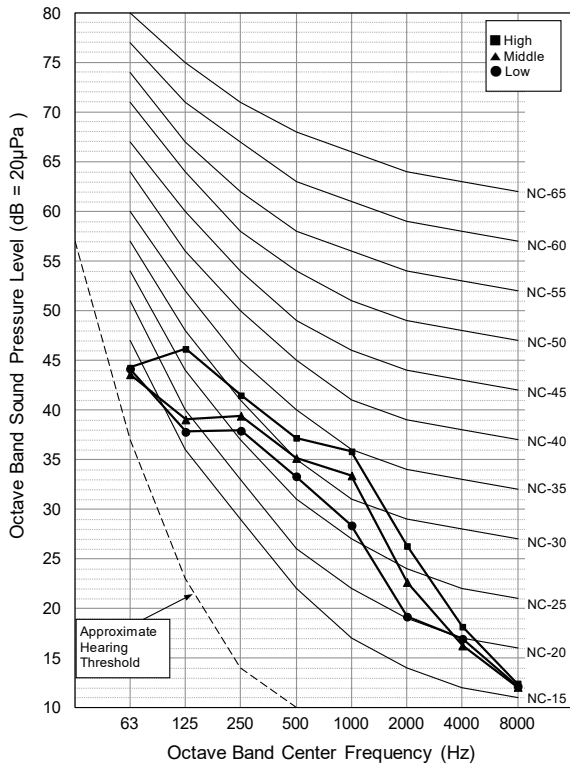

Sound level [dB(A), @ Standard condition]	
Cooling ((SH)/H/M/L)	- / 38.0 / 36.0 / 34.0
Heating ((SH)/H/M/L)	- / 38.0 / 36.0 / 34.0

Note

- Sound measured at some distance away from the center of the unit.
- Data is valid at free field condition.
- Reference acoustic pressure 0dB = 20µPa.
- Data is valid at nominal operation condition.
Refer to the Model Specifications for nominal conditions(Power source and Ambient temperature, etc)
- Sound levels can be increased in accordance with installation and operating conditions.
(Static pressure mode, used air guide, Room target temperature setting, etc)
- Sound pressure level is measured on the rated condition in the anechoic rooms by ISO 3745 standard.
Therefore, these values can be increased owing to ambient conditions during operation.

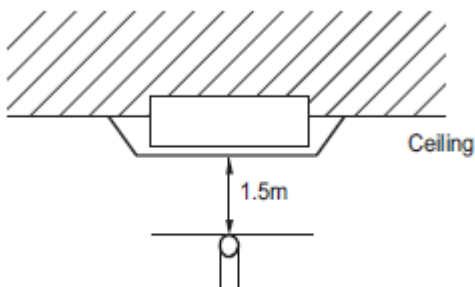

* Measuring place : Anechoic chamber

2. ATNW24GPLP1

2.8 Air flow and temperature distributions

2.8.1 Cooling

Discharge angle: 40°

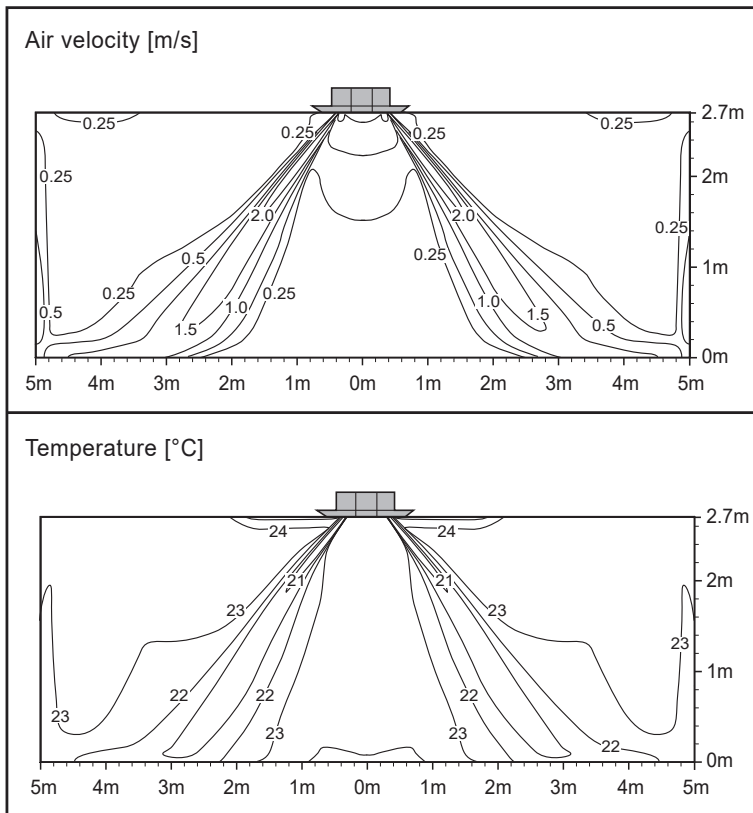

Note

- These figures are accordance with normal certain condition and environment.
(Airflow step is 'High', Air discharge angle is fixed as indicated angle.)
- Indoor airflow distribution under actual installation or operating conditions depends on ambient temperature, ceiling height, product installation direction / location, indoor / Heating load, and other obstacles, etc.

2. ATNW24GPLP1

2.8.2 Heating

Discharge angle: 50°

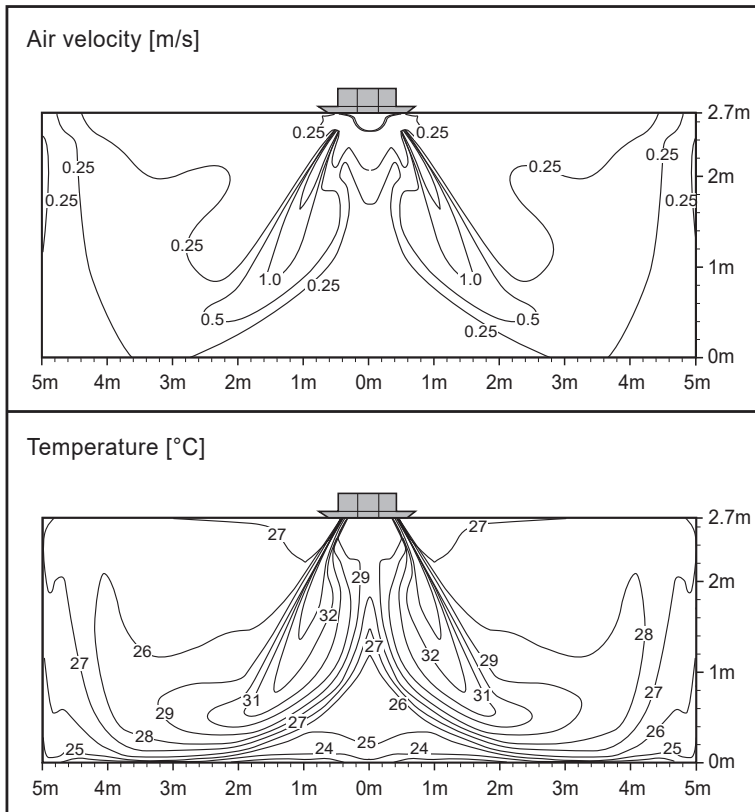

Note

- These figures are accordance with normal certain condition and environment.
(Airflow step is 'High', Air discharge angle is fixed as indicated angle.)
- Indoor airflow distribution under actual installation or operating conditions depends on ambient temperature, ceiling height, product installation direction / location, indoor / Heating load, and other obstacles, etc.

3. ATNW36GNLP1

3.1 Specifications

Category		Unit	Specification
Major	Minor		
Classification	Chassis	-	TN
Power Supply	Case 1	-	220, 1, 60
	Case 2	-	-
	Limit Range of Voltage(Case 1)	V	198~242
	Limit Range of Voltage(Case 2)	V	-
Cooling Capacity	Nominal	kW	9.09
		Btu/h	31,000
Heating Capacity	Nominal	kW	10.55
		Btu/h	36,000
Power Input(Indoor)	H/M/L	W	-
Running Current	H/M/L	A	-
Indoor Fan	Type	-	2D Turbo
	Quantity	EA	1
	Air Flow Rate((SH)/H/M/L)	m ³ /min	- / 23.0 / 21.0 / 19.0
	Air Flow Rate Range(Min~Max)	m ³ /min	19.0~23.0
	External Static Pressure_Factory Set	Pa	-
Indoor Fan Motor	Type	-	BLDC
	Drive	-	-
	Output	W	124
		No.	1
Dehumidification Rate	-	ℓ/h	2.50
Heat Exchanger	Rows x Columns x FPI	-	2 x 10 x 19
	No.	-	1
	Fin Type	-	Louver
	Face Area	m ²	0.43
Dimensions	Net(W x H x D)	mm	840 x 246 x 840
	Shipping(W x H x D)	mm	922 x 318 x 917
Weight	Net	kg	25.5
	Shipping	kg	29.7
Exterior	Color	-	Morning Fog
	RAL (Classic)	-	RAL 9001
Air Filter	Type	-	Long Life
Protection Device	Fuse	-	O
	Overload Protector for Fan Motor	-	Thermal Protector for Fan Motor
Refrigerant	Type	-	R410A
	Control Type	-	-
Drain Pipe(Natural Drainage)	O.D / I.D	mm(inch)	-
Drain Pipe(using Drain Pump)	O.D / I.D	mm(inch)	32.0 / 25.0
Pipe Connecting Socket	Liquid	mm(inch)	Φ9.52 (3/8)
	Gas	mm(inch)	Φ15.88 (5/8)
	Connection Type(Liquid)	-	Flare
	Connection Type(Gas)	-	Flare
Sound Pressure Level(Indoor Unit)	Cooling ((SH)/H/M/L)	dB(A)	- / 40.0 / 38.0 / 36.0
	Heating ((SH)/H/M/L)	dB(A)	- / 40.0 / 38.0 / 36.0
Measurement Standard (Pressure Level)	-	-	ISO 3745
Sound Power Level(Indoor Unit)	Cooling ((SH)/H/M/L)	dB(A)	-
	Heating ((SH)/H/M/L)	dB(A)	-
Measurement Standard (Power Level)	-	-	-
Connecting Cable	Power and Communication cable(H07RN-F)	mm ² × cores	0.75 x 4

3. ATNW36GNLP1

Category		Unit	Specification
Major	Minor		
Power Supply Type to Indoor	-	-	-
Electrical Characteristic	Maximum Fuse Amperes (MFA)	A	25
	Indoor Fan Motor_Full Load Amperes (FLA / Max)	A	0.8

Note

- Due to our policy of innovation some specifications may be changed without notification.
- Wiring cable size must comply with the applicable local and national code.
And "Electric characteristics" should be considered for electrical work and design.
- Especially the power cable and circuit breaker should be selected in accordance with that.
- Sound Level Values are measured at Noise Measuring chamber accordance with standard.
Therefore, these values depend on the ambient conditions and values are normally higher in actual operation.

3. ATNW36GNLP1

3.2 List of Functions

Category	Functions	Availability
Air Flow	Air Supply Outlet	4
	Airflow Direction Control (left & right)	X
	Airflow Direction Control (up & down)	Auto
	Auto Swing (left & right)	X
	Auto Swing (up & down)	O
	Airflow Steps (fan/cool/heat)	4 / 5 / 4
	Fan Speed Auto*	X
	Power Cool/Heat	O / X
	Swirl Wind*	O
	Refresh Mode**	X
	Smart Mode**	X
	Indirect Wind*	O
	Direct Wind*	O
	Dry Operation	O
Air Purification	Air Purify	Accessory
	Ionizer	X
	UV-C	X
	Allergy Filter	X
	Pre-Filter	O
	PM1.0 Filter	X
Reliability	Hot Start	O
	Self Diagnosis	O
Convenience	Auto Mode	O
	Auto Dry Operation**	X
	Auto Restart	O
	Child Lock*	O
	Forced Operation	O
	Group Control*	O
	Sleep Timer**	O
	Turn On/Off Reservation**	O
	Schedule**	O
	Two Thermistor Control*	O
	Time Limit Control (Energy saving)***	O
External On/Off	O	
Installation	Drain Pump	O
	High Ceiling Operation*	O
Special Functions	Wi-Fi Control	Accessory
	Comfort Cooling (Humidity Control)***	O
	Auto Elevation Grille	Accessory(PTEGM0)
	Human Detection Function***	Accessory
	Floor Detection Function***	X

Note

- O : Applied, X : Not Applied, - : Unconfirmed or irrelevant
- Embedded : A kit is provided by default for using this function when the product is manufactured.
- Accessory : Ordered and purchased separately the accessory package referring to the model name provided and install at field.
- Accessory line-ups varies by region, so check your local catalogue or local sales material.
- Some functions can be limited by remote controller.
- In case of cassette type indoor units, Plasma kit and Auto Elevation Grille functions are not applicable at the same time.
- 'Auto Mode' varies depending on the outdoor unit type.
 - Auto Change Over(Single Heat Pump Outdoor Unit)
 - Auto Mode Select(Multi Heat Pump Outdoor Unit)

3. ATNW36GNLP1

- Auto Intensity Control(Cooling Only Outdoor Unit)
- * : These functions need to connect the wired remote controller.
- ** : This functions need to connect to the Standard II / III wired remote controller.
- *** : This functions need to connect to the Standard III wired remote controller.

3. ATNW36GNLP1

3.3 Accessory Compatibility List

Category	Accessory Name	Model Name	Description	Compatibility
Remote Controller	Wired - Premium	PREMTA000	-	O
		PREMTA000A	-	O
		PREMTA000B	-	O
	Wired - RS3 (Standard III)	PREMTB100	White	O
		PREMTBB10	Black	O
	Wired - RS2 (Standard II)	PREMTB001	White	O
		PREMTBB01	Black	O
	Wired - Simple	PQRCVCL0QW	White	O
		PQRCVCL0Q	Black	O
	Wired - Simple for hotel	PQRCHCA0QW	White	O
		PQRCHCA0Q	Black	O
	Wireless	PQWRQC0FDB	For Cooling only	O
		PQWRHQ0FDB	For Heat pump	O
		PWLSSB21C	For Cooling only	O
PWLSSB21H		For Heat pump	O	
Dry Contact	Simple	PDRYCB000	1 input port, AC 220 - 240V	O
		PDRYCB100	1 input port, AC 24V	O
	Communication	PDRYCB400	2 input port	O
		PDRYCB300	8 input port, For 3rd party Thermostat	O
		PDRYCB320	8 input port, For 3rd Party Thermostat (Analog Input)	O
PDRYCB500	For 3rd Party Controller(Modbus RTU)	O		
Integration Device	Remote Temperature sensor	PQRSTA0	-	O
	Group Control wire	PZCWRCG3	Cable Assembly for group control (Y-type cable : 0.25m, cable : 9.6m)	O
ETC	Extension wire	PZCWRC1	Extension wire for IDU-wired remote controller (9.6m)	O
	2-Remo Control wire	PZCWRC2	-	X
	Wi-Fi Modem	PWFMD200	-	O
	Wi-Fi Extension cable	PWYREW000	USB Extension cable : 10 m	O
	Independent Power Module	PRIP0	For Multi V Indoor Unit	X
	Multi-tenant Power module	PINPMB001	For Multi V Indoor Unit	X
	Refrigerant Leakage Detector	PRLDNVS0	For Multi V Indoor Unit (R410A)	X
	Human Detection Sensor	PTVSMA0	For Cassette 4-way	O
		PTVSAA0	For Cassette Dual Vane 4-way	X
	Floor Detection Sensor	PTFSMA0	For Cassette Dual Vane 4-way	X
	Auto Elevation Grille	PTEGM0	For Cassette 4-way	X
	Air Purification Kit	PTAHTP0	For Cassette 1-way	X
		PTAHMP0	For Cassette 4-way	O
		PTAHYP0	For Cassette Round	X
	EEV Kit	PRGK024A0	For Multi V Indoor Unit	X
	Auxiliary Heater Relay Kit	PRARS1	For Wall Mounted / Art Cool Indoor Units	X
		PRARH1	For Cassette / Duct Indoor Units	X
	Ventilation Kit	PTVK430	For TR/TQ/TP/TN/TM Chassis	X
		PTVK410 / PTVK420	For TP/TN/TM Chassis	X
	Cassette Cover	PTDCQ	For TR/TQ Chassis	X
		PTDCM	For TP/TN/TM Chassis	X
PTDCA		For TM-A/TP-B Chassis	X	

Note

- O: Possible, X: Impossible, -: Unconfirmed or irrelevant.
- *: Some advanced functions controlled by individual controller cannot be operated.
- Air Purification Kit and Auto Elevation Grille are not applicable at the same time.
- If there is a difference in development time between the product and the remote controller, some functions cannot be operated.
- If you need more detail, please refer to the Control(BECON) PDB or the manual of product.
(<http://partner.lge.com/global> : Home> Doc.Library> Product > Control(BECON)).

3. ATNW36GNLP1

3.4 Dimensions

3.4.1 Product

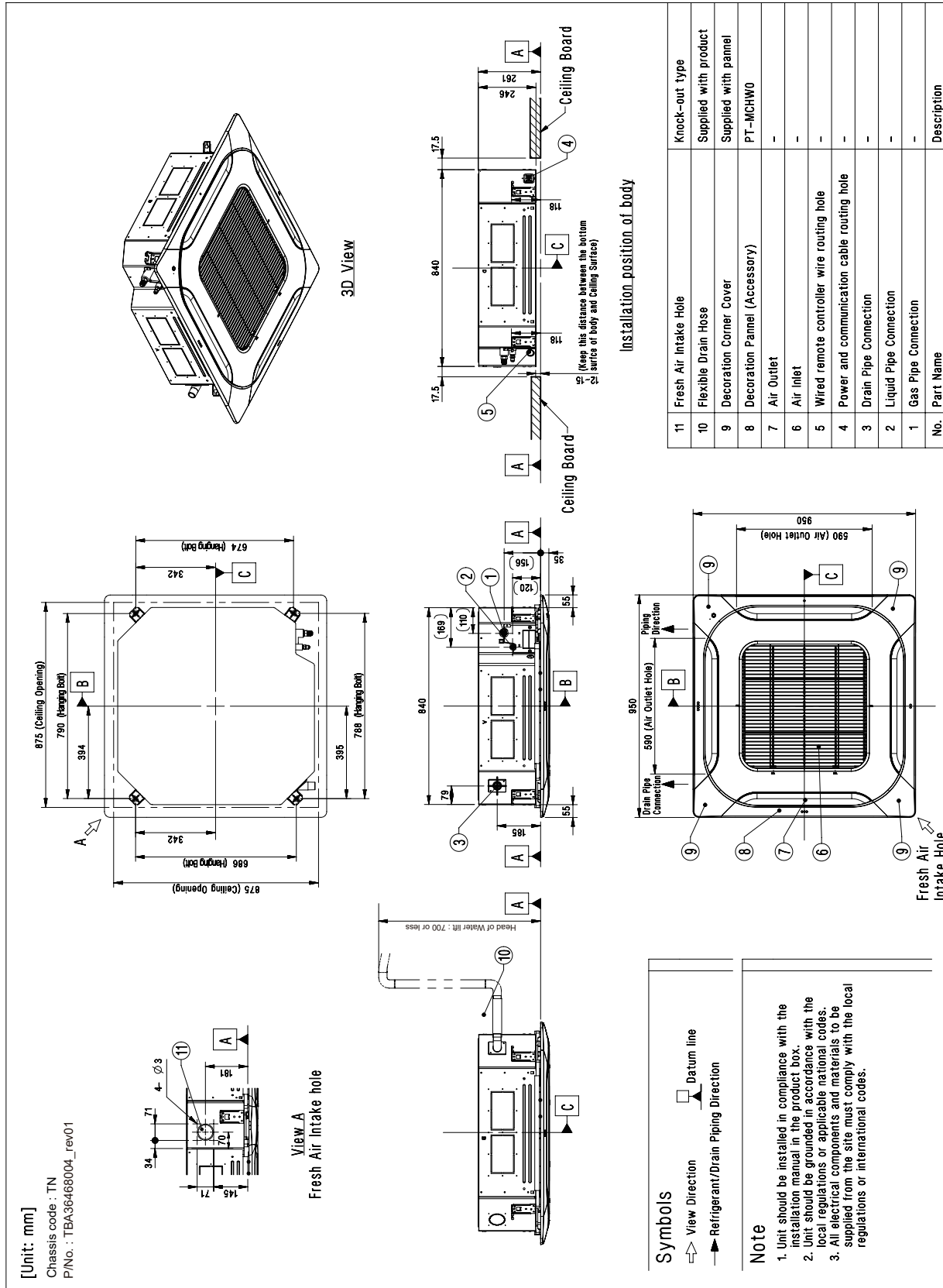

3. ATNW36GNLP1

3.4.2 Install Space

< Minimum Installation Space >

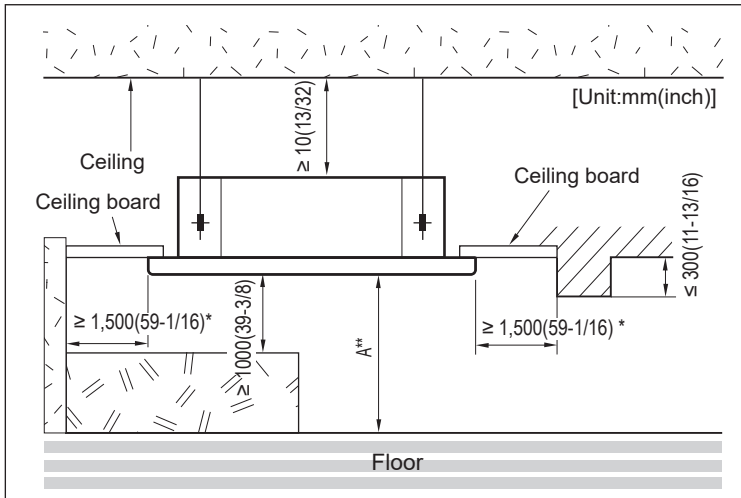

Notes

1. *: Minimum Installation Space to Air flow direction
A separation distance of at least 1,500 mm is required throughout the airflow direction.

2. **: A, Installation Height from the floor

Capacity Class	Installation Height (A)		
	Min.	Standard ***	Max.
< 10 kW	2.0 m (6.56 ft)	2.7 m (8.86 ft)	3.6 m (11.81 ft)
≥ 10 kW	2.5 m (8.20 ft)	3.2 m (10.50 ft)	4.2 m (13.78 ft)

*** : Standard Height (Recommended)

If it exceeds the standard height, set the 'High Ceiling Mode'.

For details about function setting, refer to the installation manual.

< Cautions for Panel installation >

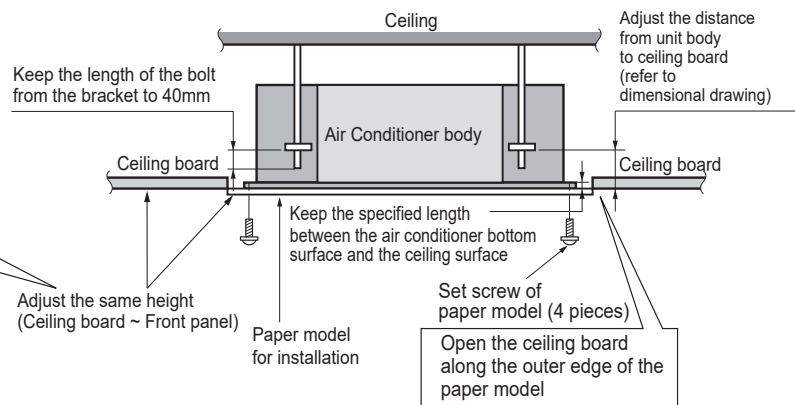
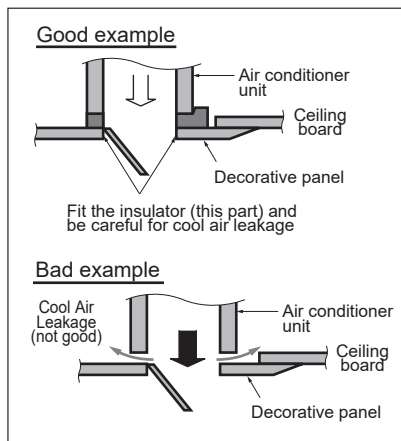

< Series installation >

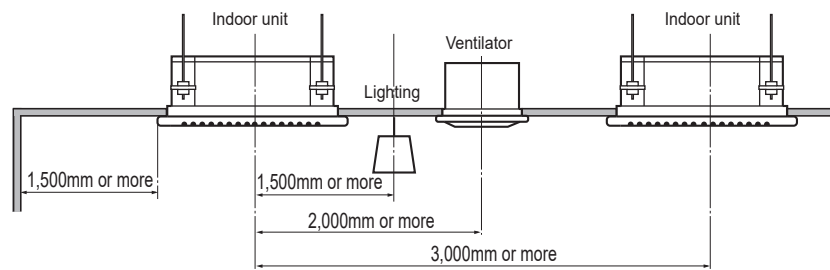

※ According to type of indoor unit, external appearance could be different.

Note

- Places where products are installed should not be any obstacles to the air circulation or installation. Ensure the spaces from the wall, ceiling, or other obstacles.
- According to type of indoor unit, external appearance or installed structure could be different.
- According to product type, model line up, sales region..etc, applicability of each chassis could be different.
- Install certainly the decoration panel. Cool air leakage causes sweating or falling of water-drops.

3. ATNW36GNLP1

3.5 Piping Diagrams

3.5.1 Normal

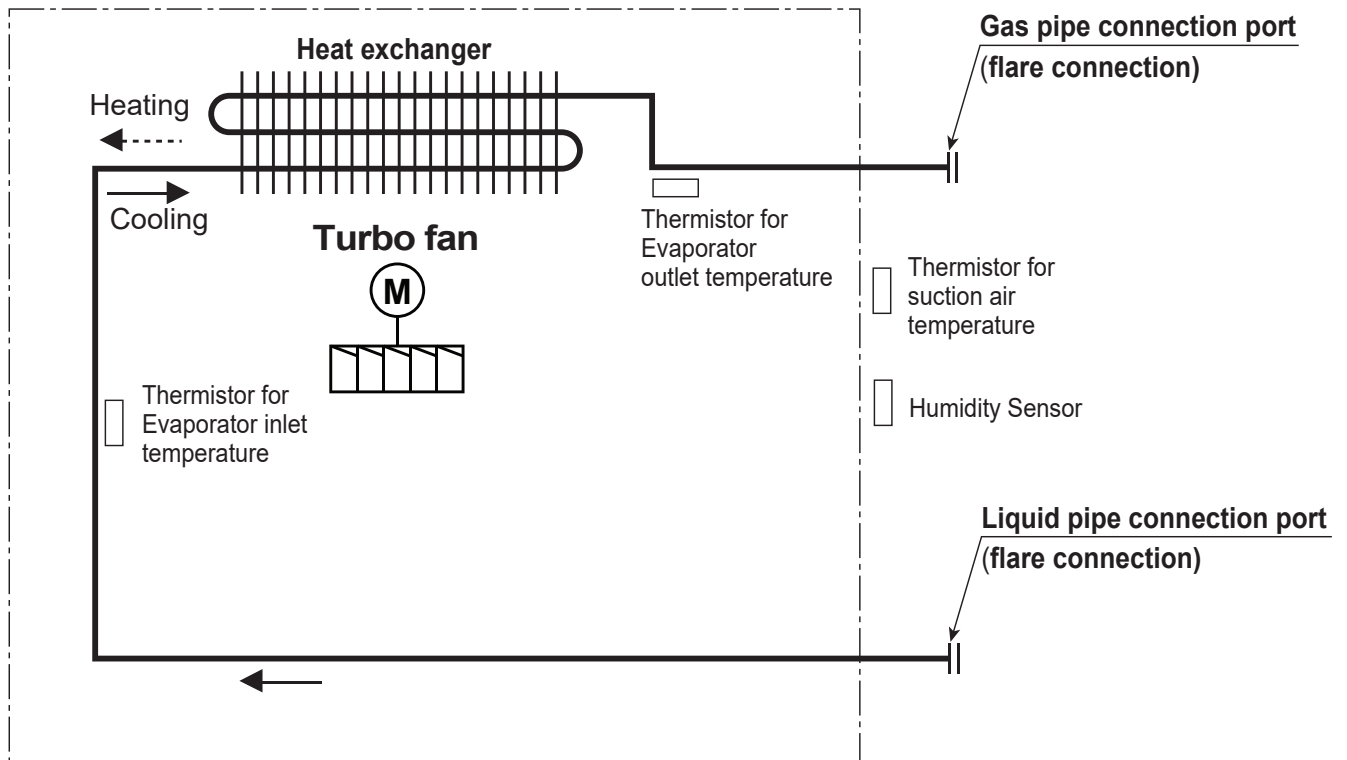

3. ATNW36GNLP1

3.6 Wiring Diagrams

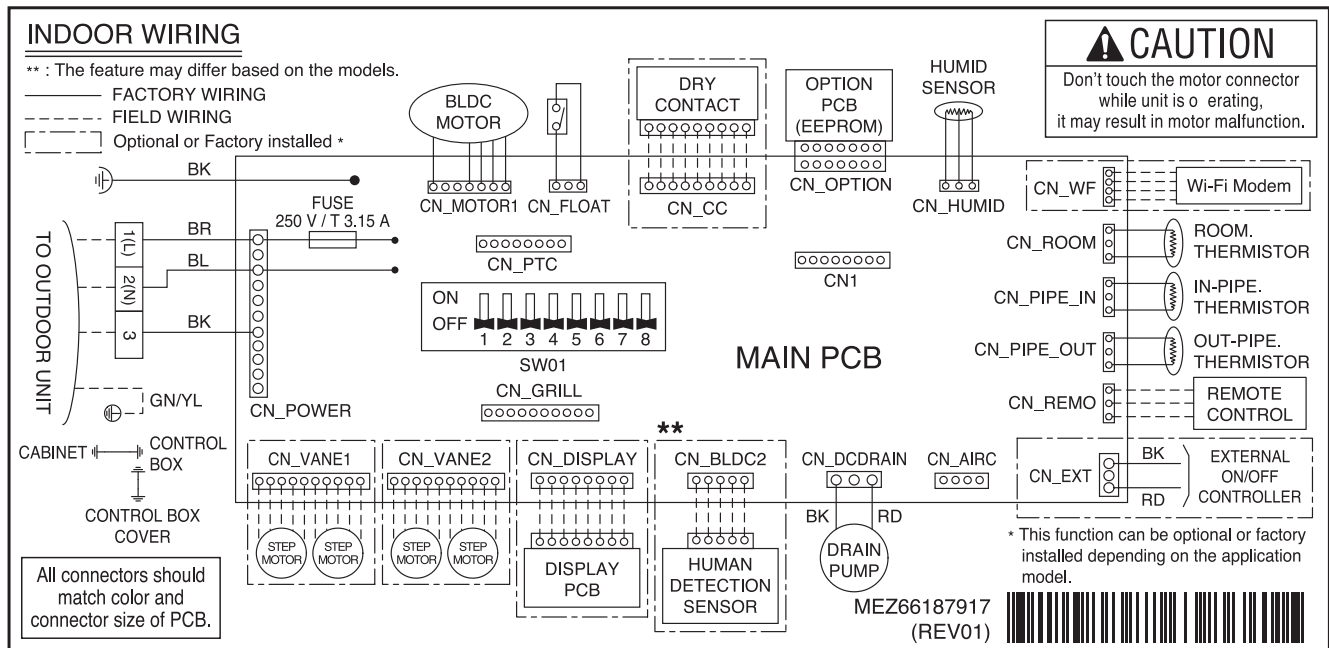

3. ATNW36GNLP1

3.7 Sound Levels

3.7.1 Pressure Levels

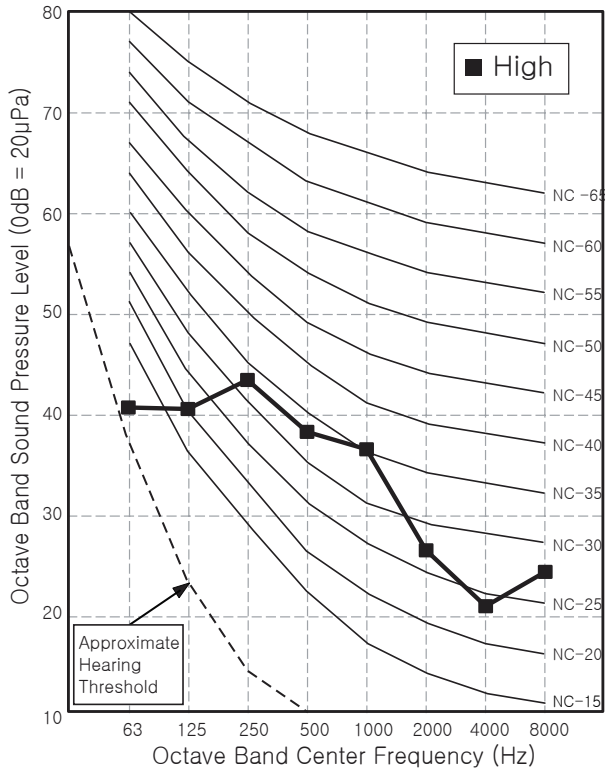

Sound level [dB(A), @ Standard condition]	
Cooling ((SH)/H/M/L)	- / 40.0 / 38.0 / 36.0
Heating ((SH)/H/M/L)	- / 40.0 / 38.0 / 36.0

Note

- Sound measured at some distance away from the center of the unit.
- Data is valid at free field condition.
- Reference acoustic pressure 0dB = 20µPa.
- Data is valid at nominal operation condition.
Refer to the Model Specifications for nominal conditions(Power source and Ambient temperature, etc)
- Sound levels can be increased in accordance with installation and operating conditions.
(Static pressure mode, used air guide, Room target temperature setting, etc)
- Sound pressure level is measured on the rated condition in the anechoic rooms by ISO 3745 standard.
Therefore, these values can be increased owing to ambient conditions during operation.

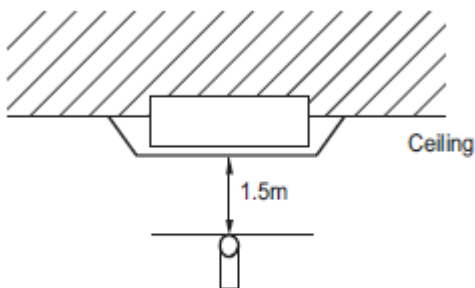

* Measuring place : Anechoic chamber

3. ATNW36GNLP1

3.8 Air flow and temperature distributions

3.8.1 Cooling

Discharge angle: 40°

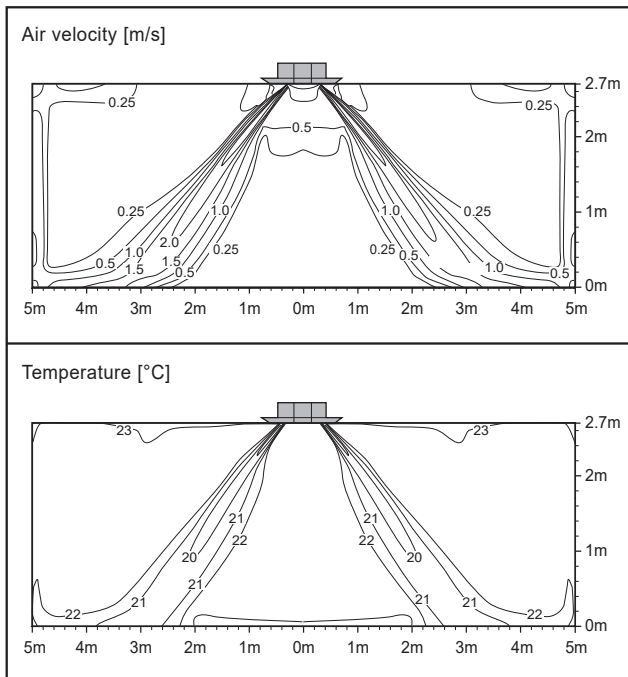

Note

- These figures are accordance with normal certain condition and environment.
(Airflow step is 'High', Air discharge angle is fixed as indicated angle.)
- Indoor airflow distribution under actual installation or operating conditions depends on ambient temperature, ceiling height, product installation direction / location, indoor / Heating load, and other obstacles, etc.

3. ATNW36GNLP1

3.8.2 Heating

Discharge angle: 50°

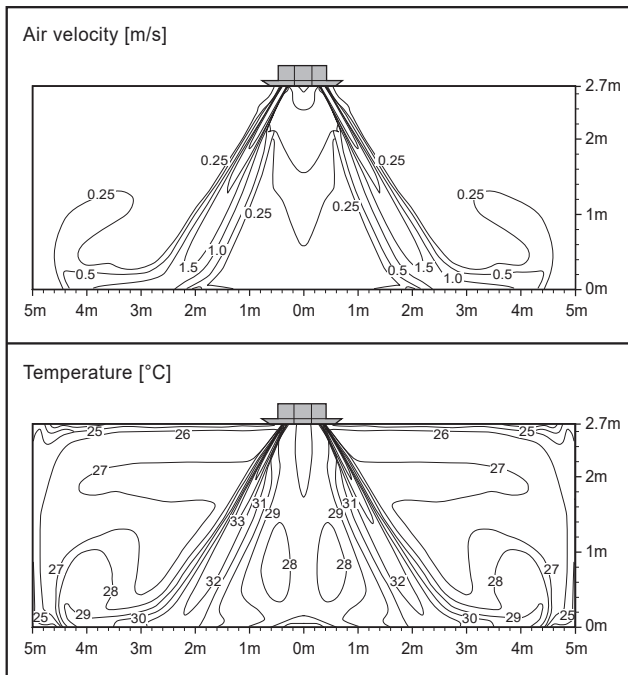

Note

- These figures are accordance with normal certain condition and environment.
(Airflow step is 'High', Air discharge angle is fixed as indicated angle.)
- Indoor airflow distribution under actual installation or operating conditions depends on ambient temperature, ceiling height, product installation direction / location, indoor / Heating load, and other obstacles, etc.

4. ATNW48GMLP1

4.1 Specifications

Category		Unit	Specification
Major	Minor		
Classification	Chassis	-	TM
Power Supply	Case 1	-	220, 1, 60
	Case 2	-	-
	Limit Range of Voltage(Case 1)	V	198~242
	Limit Range of Voltage(Case 2)	V	-
Cooling Capacity	Nominal	kW	13.78
		Btu/h	47,000
Heating Capacity	Nominal	kW	15.53
		Btu/h	53,000
Power Input(Indoor)	H/M/L	W	-
Running Current	H/M/L	A	-
Indoor Fan	Type	-	2D Turbo
	Quantity	EA	1
	Air Flow Rate((SH)/H/M/L)	m ³ /min	- / 31.0 / 28.0 / 25.0
	Air Flow Rate Range(Min~Max)	m ³ /min	25.0~31.0
	External Static Pressure_Factory Set	Pa	-
Indoor Fan Motor	Type	-	BLDC
	Drive	-	-
	Output	W	124
		No.	1
Dehumidification Rate	-	ℓ/h	5.20
Heat Exchanger	Rows x Columns x FPI	-	3 x 12 x 19
	No.	-	1
	Fin Type	-	Louver
	Face Area	m ²	0.53
Dimensions	Net(W x H x D)	mm	840 x 288 x 840
	Shipping(W x H x D)	mm	922 x 360 x 917
Weight	Net	kg	28.5
	Shipping	kg	33.0
Exterior	Color	-	Morning Fog
	RAL (Classic)	-	RAL 9001
Air Filter	Type	-	Long Life
Protection Device	Fuse	-	O
	Overload Protector for Fan Motor	-	Thermal Protector for Fan Motor
Refrigerant	Type	-	R410A
	Control Type	-	-
Drain Pipe(Natural Drainage)	O.D / I.D	mm(inch)	-
Drain Pipe(using Drain Pump)	O.D / I.D	mm(inch)	32.0 / 25.0
Pipe Connecting Socket	Liquid	mm(inch)	Φ9.52 (3/8)
	Gas	mm(inch)	Φ19.05 (3/4)
	Connection Type(Liquid)	-	Flare
	Connection Type(Gas)	-	Flare
Sound Pressure Level(Indoor Unit)	Cooling ((SH)/H/M/L)	dB(A)	- / 47.0 / 45.0 / 42.0
	Heating ((SH)/H/M/L)	dB(A)	- / 47.0 / 45.0 / 42.0
Measurement Standard (Pressure Level)	-	-	ISO 3745
Sound Power Level(Indoor Unit)	Cooling ((SH)/H/M/L)	dB(A)	-
	Heating ((SH)/H/M/L)	dB(A)	-
Measurement Standard (Power Level)	-	-	-
Connecting Cable	Power and Communication cable(H07RN-F)	mm ² × cores	0.75 x 4

4. ATNW48GMLP1

Category		Unit	Specification
Major	Minor		
Power Supply Type to Indoor	-	-	-
Electrical Characteristic	Maximum Fuse Amperes (MFA)	A	40
	Indoor Fan Motor_Full Load Amperes (FLA / Max)	A	0.8

Note

- Due to our policy of innovation some specifications may be changed without notification.
- Wiring cable size must comply with the applicable local and national code.
And "Electric characteristics" should be considered for electrical work and design.
- Especially the power cable and circuit breaker should be selected in accordance with that.
- Sound Level Values are measured at Noise Measuring chamber accordance with standard.
Therefore, these values depend on the ambient conditions and values are normally higher in actual operation.

4. ATNW48GMLP1

4.2 List of Functions

Category	Functions	Availability
Air Flow	Air Supply Outlet	4
	Airflow Direction Control (left & right)	X
	Airflow Direction Control (up & down)	Auto
	Auto Swing (left & right)	X
	Auto Swing (up & down)	O
	Airflow Steps (fan/cool/heat)	4 / 5 / 4
	Fan Speed Auto*	X
	Power Cool/Heat	O / X
	Swirl Wind*	O
	Refresh Mode**	X
	Smart Mode**	X
	Indirect Wind*	O
	Direct Wind*	O
	Dry Operation	O
Air Purification	Air Purify	Accessory
	Ionizer	X
	UV-C	X
	Allergy Filter	X
	Pre-Filter	O
	PM1.0 Filter	X
Reliability	Hot Start	O
	Self Diagnosis	O
Convenience	Auto Mode	O
	Auto Dry Operation**	X
	Auto Restart	O
	Child Lock*	O
	Forced Operation	O
	Group Control*	O
	Sleep Timer**	O
	Turn On/Off Reservation**	O
	Schedule**	O
	Two Thermistor Control*	O
	Time Limit Control (Energy saving)***	O
External On/Off	O	
Installation	Drain Pump	O
	High Ceiling Operation*	O
Special Functions	Wi-Fi Control	Accessory
	Comfort Cooling (Humidity Control)***	O
	Auto Elevation Grille	Accessory(PTEGM0)
	Human Detection Function***	Accessory
	Floor Detection Function***	X

Note

- O : Applied, X : Not Applied, - : Unconfirmed or irrelevant
- Embedded : A kit is provided by default for using this function when the product is manufactured.
- Accessory : Ordered and purchased separately the accessory package referring to the model name provided and install at field.
- Accessory line-ups varies by region, so check your local catalogue or local sales material.
- Some functions can be limited by remote controller.
- In case of cassette type indoor units, Plasma kit and Auto Elevation Grille functions are not applicable at the same time.
- 'Auto Mode' varies depending on the outdoor unit type.
 - Auto Change Over(Single Heat Pump Outdoor Unit)
 - Auto Mode Select(Multi Heat Pump Outdoor Unit)

4. ATNW48GMLP1

- Auto Intensity Control(Cooling Only Outdoor Unit)
- * : These functions need to connect the wired remote controller.
- ** : This functions need to connect to the Standard II / III wired remote controller.
- *** : This functions need to connect to the Standard III wired remote controller.

4. ATNW48GMLP1

4.3 Accessory Compatibility List

Category	Accessory Name	Model Name	Description	Compatibility
Remote Controller	Wired - Premium	PREMTA000	-	O
		PREMTA000A	-	O
		PREMTA000B	-	O
	Wired - RS3 (Standard III)	PREMTB100	White	O
		PREMTBB10	Black	O
	Wired - RS2 (Standard II)	PREMTB001	White	O
		PREMTBB01	Black	O
	Wired - Simple	PQRCVCL0QW	White	O
		PQRCVCL0Q	Black	O
	Wired - Simple for hotel	PQRCHCA0QW	White	O
		PQRCHCA0Q	Black	O
	Wireless	PQWRQC0FDB	For Cooling only	O
		PQWRHQ0FDB	For Heat pump	O
		PWLSSB21C	For Cooling only	O
		PWLSSB21H	For Heat pump	O
Dry Contact	Simple	PDRYCB000	1 input port, AC 220 - 240V	O
		PDRYCB100	1 input port, AC 24V	O
	Communication	PDRYCB400	2 input port	O
		PDRYCB300	8 input port, For 3rd party Thermostat	O
		PDRYCB320	8 input port, For 3rd Party Thermostat (Analog Input)	O
PDRYCB500	For 3rd Party Controller(Modbus RTU)	O		
Integration Device	Remote Temperature sensor	PQRSTA0	-	O
	Group Control wire	PZCWRCG3	Cable Assembly for group control (Y-type cable : 0.25m, cable : 9.6m)	O
ETC	Extension wire	PZCWRC1	Extension wire for IDU-wired remote controller (9.6m)	O
	2-Remo Control wire	PZCWRC2	-	X
	Wi-Fi Modem	PWFMD200	-	O
	Wi-Fi Extension cable	PWYREW000	USB Extension cable : 10 m	O
	Independent Power Module	PRIP0	For Multi V Indoor Unit	X
	Multi-tenant Power module	PINPMB001	For Multi V Indoor Unit	X
	Refrigerant Leakage Detector	PRLDNVS0	For Multi V Indoor Unit (R410A)	X
	Human Detection Sensor	PTVSMA0	For Cassette 4-way	O
		PTVSAA0	For Cassette Dual Vane 4-way	X
	Floor Detection Sensor	PTFSMA0	For Cassette Dual Vane 4-way	X
	Auto Elevation Grille	PTEGM0	For Cassette 4-way	X
	Air Purification Kit	PTAHTP0	For Cassette 1-way	X
		PTAHMP0	For Cassette 4-way	O
		PTAHYP0	For Cassette Round	X
	EEV Kit	PRGK024A0	For Multi V Indoor Unit	X
	Auxiliary Heater Relay Kit	PRARS1	For Wall Mounted / Art Cool Indoor Units	X
		PRARH1	For Cassette / Duct Indoor Units	X
	Ventilation Kit	PTVK430	For TR/TQ/TP/TN/TM Chassis	X
		PTVK410 / PTVK420	For TP/TN/TM Chassis	X
	Cassette Cover	PTDCQ	For TR/TQ Chassis	X
PTDCM		For TP/TN/TM Chassis	X	
PTDCA		For TM-A/TP-B Chassis	X	

Note

- O: Possible, X: Impossible, -: Unconfirmed or irrelevant.
- *: Some advanced functions controlled by individual controller cannot be operated.
- Air Purification Kit and Auto Elevation Grille are not applicable at the same time.
- If there is a difference in development time between the product and the remote controller, some functions cannot be operated.
- If you need more detail, please refer to the Control(BECON) PDB or the manual of product.
(<http://partner.lge.com/global> : Home> Doc.Library> Product > Control(BECON)).

4. ATNW48GMLP1

4.4 Dimensions

4.4.1 Product

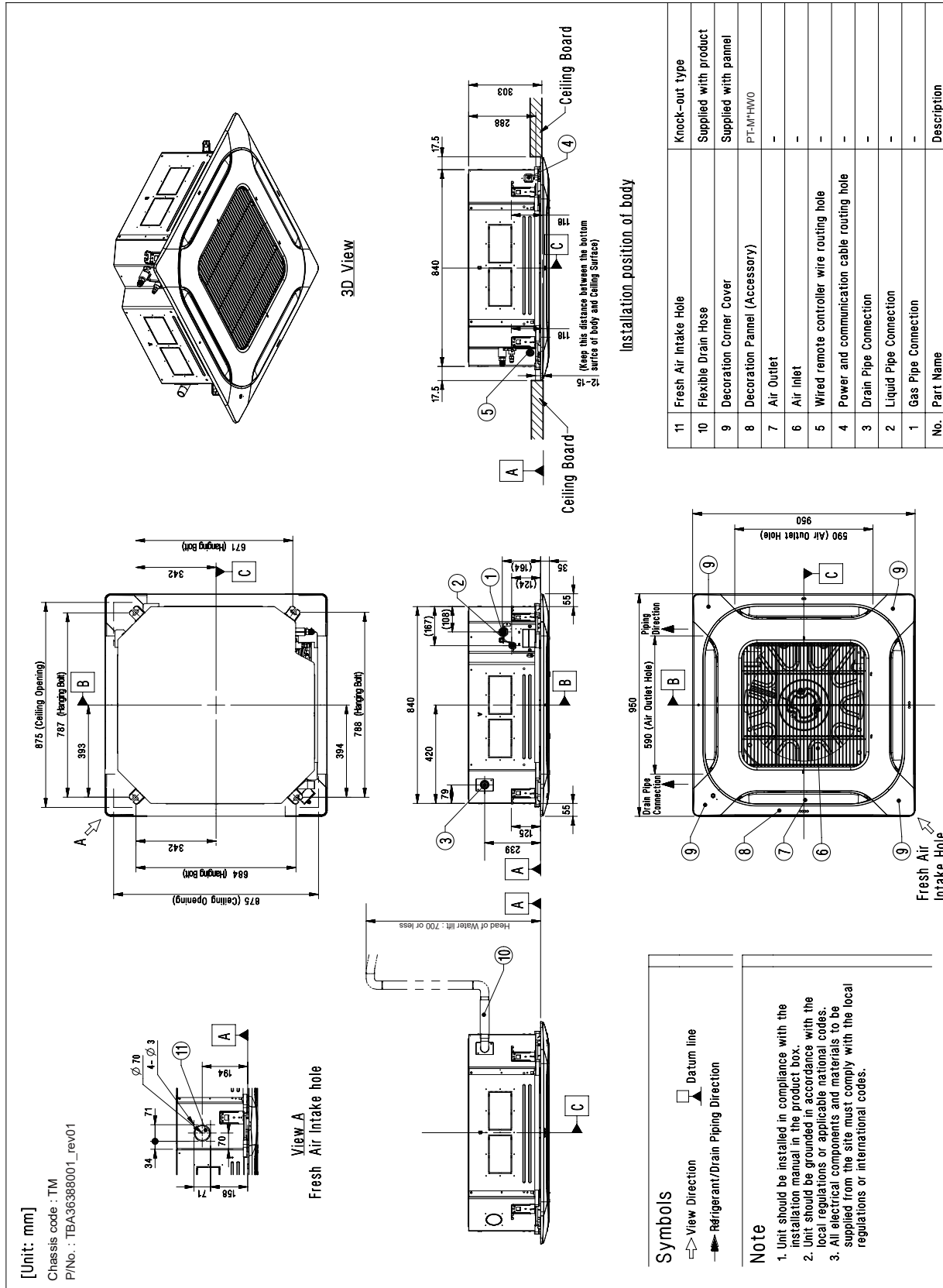

4. ATNW48GMLP1

4.4.2 Install Space

< Minimum Installation Space >

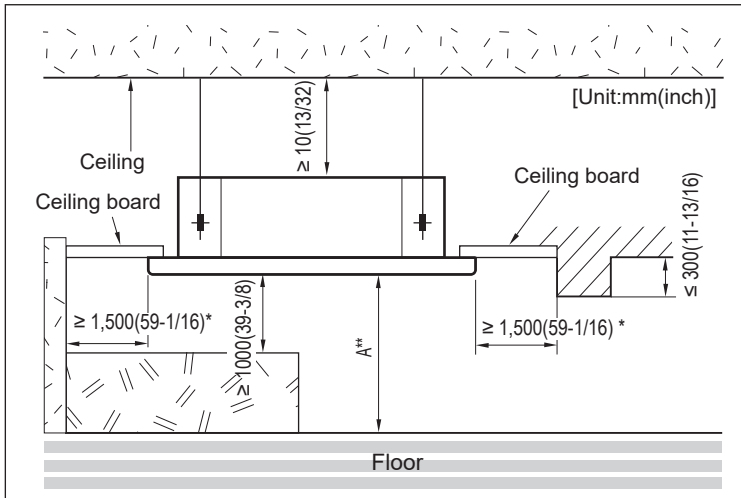

Notes

1. *: Minimum Installation Space to Air flow direction
A separation distance of at least 1,500 mm is required throughout the airflow direction.

2. **: A, Installation Height from the floor

Capacity Class	Installation Height (A)		
	Min.	Standard ***	Max.
< 10 kW	2.0 m (6.56 ft)	2.7 m (8.86 ft)	3.6 m (11.81 ft)
≥ 10 kW	2.5 m (8.20 ft)	3.2 m (10.50 ft)	4.2 m (13.78 ft)

*** : Standard Height (Recommended)

If it exceeds the standard height, set the 'High Ceiling Mode'.

For details about function setting, refer to the installation manual.

< Cautions for Panel installation >

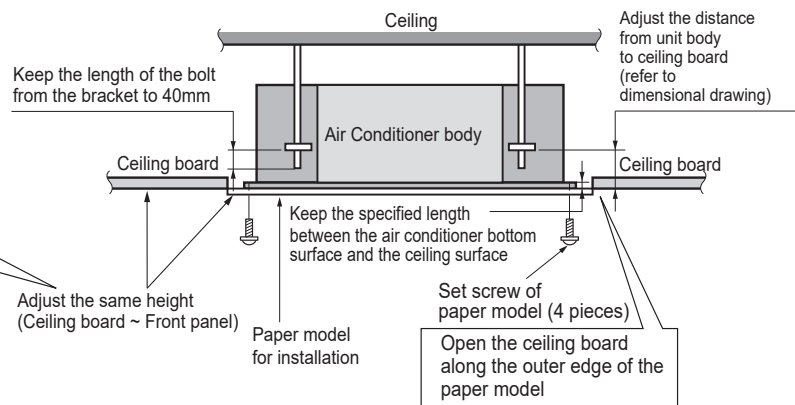
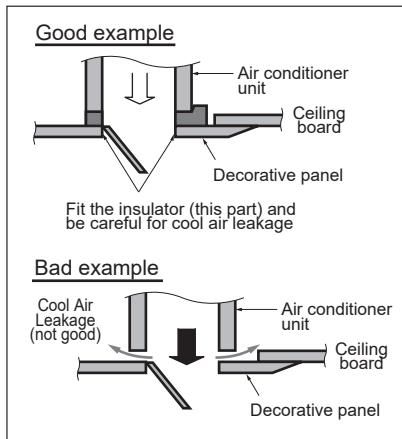

< Series installation >

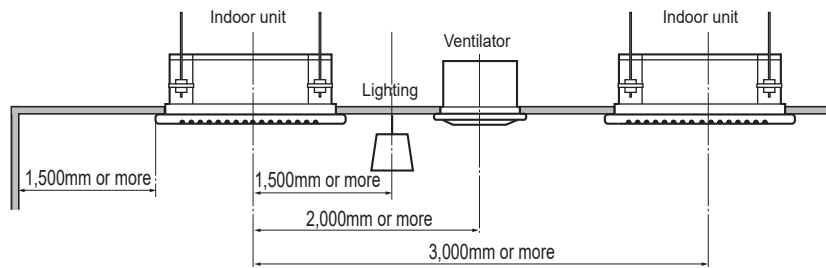

※ According to type of indoor unit, external appearance could be different.

Note

- Places where products are installed should not be any obstacles to the air circulation or installation. Ensure the spaces from the wall, ceiling, or other obstacles.
- According to type of indoor unit, external appearance or installed structure could be different.
- According to product type, model line up, sales region..etc, applicability of each chassis could be different.
- Install certainly the decoration panel. Cool air leakage causes sweating or falling of water-drops.

4. ATNW48GMLP1

4.5 Piping Diagrams

4.5.1 Normal

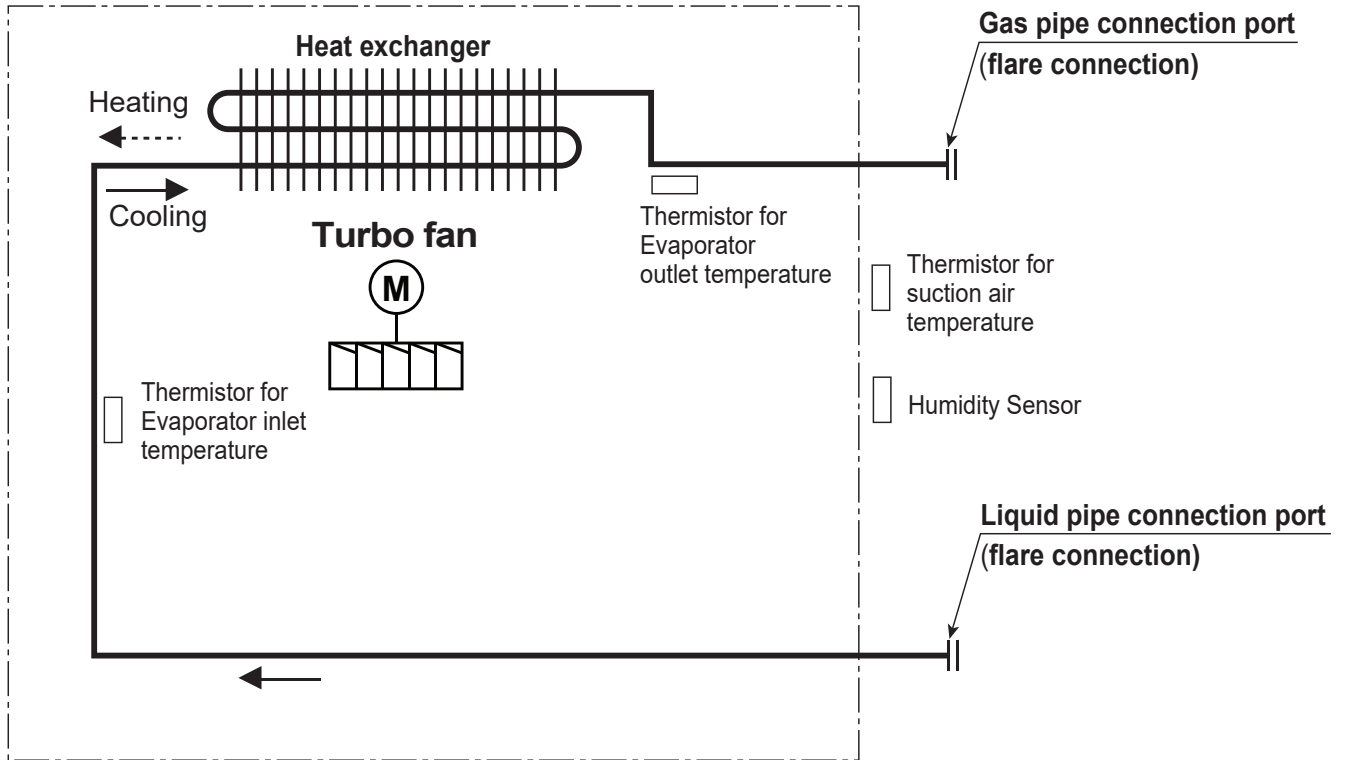

4. ATNW48GMLP1

4.6 Wiring Diagrams

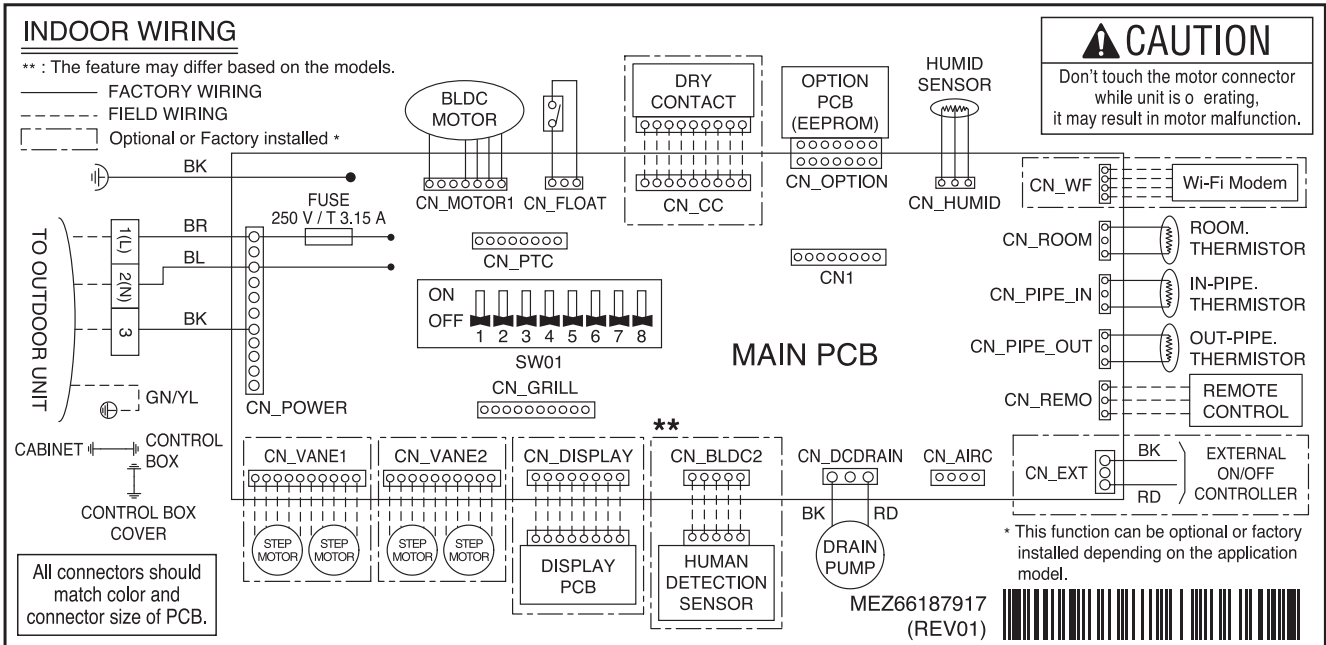

4. ATNW48GMLP1

4.7 Sound Levels

4.7.1 Pressure Levels

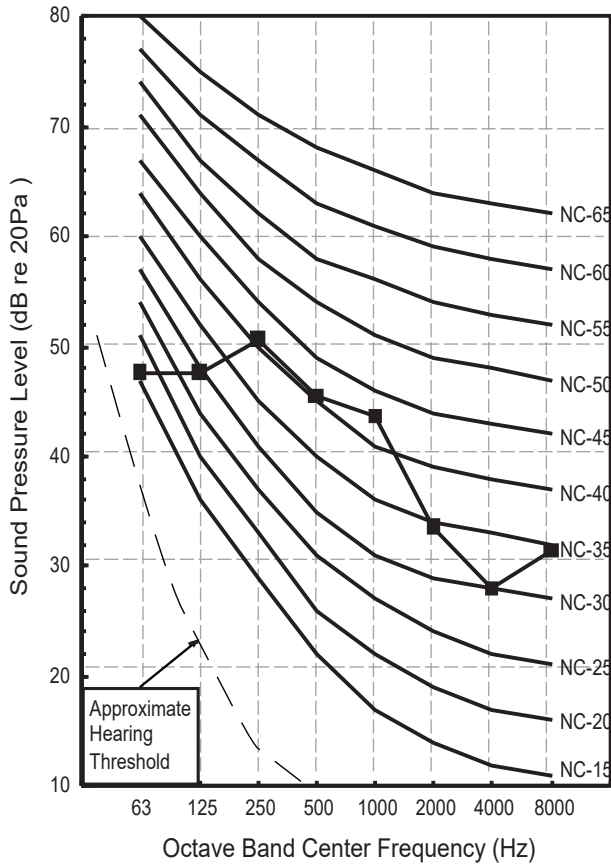

Sound level [dB(A), @ Standard condition]	
Cooling ((SH)/H/M/L)	- / 47.0 / 45.0 / 42.0
Heating ((SH)/H/M/L)	- / 47.0 / 45.0 / 42.0

Note

- Sound measured at some distance away from the center of the unit.
- Data is valid at free field condition.
- Reference acoustic pressure 0dB = 20μPa.
- Data is valid at nominal operation condition.
Refer to the Model Specifications for nominal conditions(Power source and Ambient temperature, etc)
- Sound levels can be increased in accordance with installation and operating conditions.
(Static pressure mode, used air guide, Room target temperature setting, etc)
- Sound pressure level is measured on the rated condition in the anechoic rooms by ISO 3745 standard.
Therefore, these values can be increased owing to ambient conditions during operation.

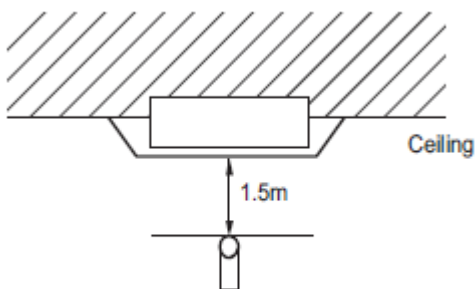

* Measuring place : Anechoic chamber

4. ATNW48GMLP1

4.8 Air flow and temperature distributions

4.8.1 Cooling

Cooling

Discharge angle: 40°

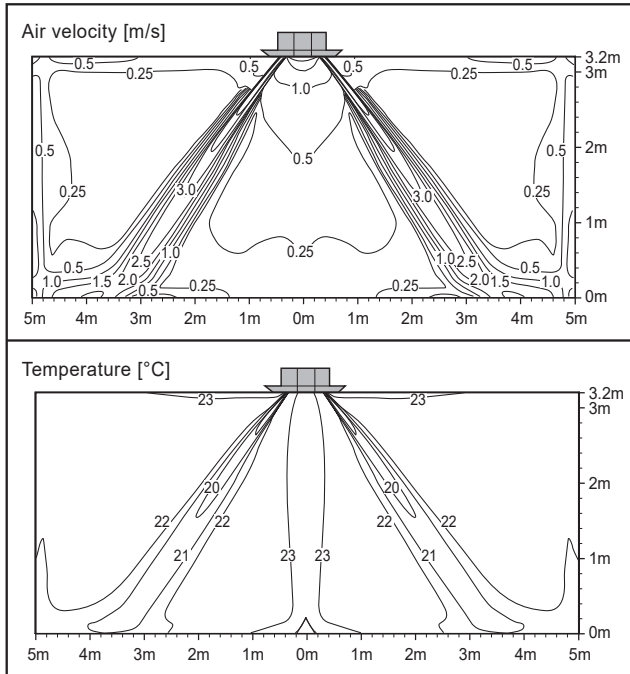

Note

- These figures are accordance with normal certain condition and environment.
(Airflow step is 'High', Air discharge angle is fixed as indicated angle.)
- Indoor airflow distribution under actual installation or operating conditions depends on ambient temperature, ceiling height, product installation direction / location, indoor / Heating load, and other obstacles, etc.

4. ATNW48GMLP1

4.8.2 Heating

Discharge angle: 50°

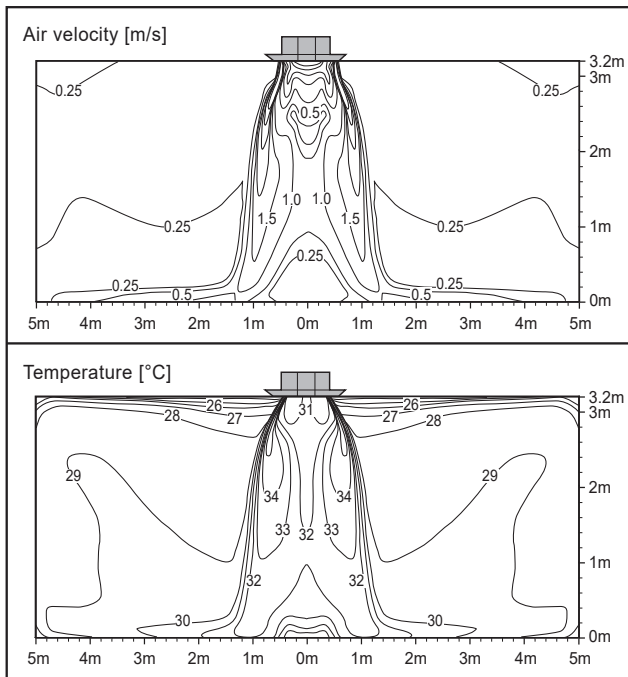

Note

- These figures are accordance with normal certain condition and environment.
(Airflow step is 'High', Air discharge angle is fixed as indicated angle.)
- Indoor airflow distribution under actual installation or operating conditions depends on ambient temperature, ceiling height, product installation direction / location, indoor / Heating load, and other obstacles, etc.

5. ATNW60GMLP1

5.1 Specifications

Category		Unit	Specification
Major	Minor		
Classification	Chassis	-	TM
Power Supply	Case 1	-	220, 1, 60
	Case 2	-	-
	Limit Range of Voltage(Case 1)	V	198~242
	Limit Range of Voltage(Case 2)	V	-
Cooling Capacity	Nominal	kW	14.65
		Btu/h	50,000
Heating Capacity	Nominal	kW	17.00
		Btu/h	58,000
Power Input(Indoor)	H/M/L	W	-
Running Current	H/M/L	A	-
Indoor Fan	Type	-	2D Turbo
	Quantity	EA	1
	Air Flow Rate((SH)/H/M/L)	m³/min	- / 31.0 / 28.0 / 25.0
	Air Flow Rate Range(Min~Max)	m³/min	25.0~31.0
	External Static Pressure_Factory Set	Pa	-
Indoor Fan Motor	Type	-	BLDC
	Drive	-	-
	Output	W	124
		No.	1
Dehumidification Rate	-	ℓ/h	6.30
Heat Exchanger	Rows x Columns x FPI	-	3 x 12 x 19
	No.	-	1
	Fin Type	-	Louver
	Face Area	m²	0.53
Dimensions	Net(W x H x D)	mm	840 x 288 x 840
	Shipping(W x H x D)	mm	922 x 360 x 917
Weight	Net	kg	28.5
	Shipping	kg	33.0
Exterior	Color	-	Morning Fog
	RAL (Classic)	-	RAL 9001
Air Filter	Type	-	Long Life
Protection Device	Fuse	-	O
	Overload Protector for Fan Motor	-	Thermal Protector for Fan Motor
Refrigerant	Type	-	R410A
	Control Type	-	-
Drain Pipe(Natural Drainage)	O.D / I.D	mm(inch)	-
Drain Pipe(using Drain Pump)	O.D / I.D	mm(inch)	32.0 / 25.0
Pipe Connecting Socket	Liquid	mm(inch)	Φ9.52 (3/8)
	Gas	mm(inch)	Φ19.05 (3/4)
	Connection Type(Liquid)	-	Flare
	Connection Type(Gas)	-	Flare
Sound Pressure Level(Indoor Unit)	Cooling ((SH)/H/M/L)	dB(A)	- / 47.0 / 45.0 / 42.0
	Heating ((SH)/H/M/L)	dB(A)	- / 47.0 / 45.0 / 42.0
Measurement Standard (Pressure Level)	-	-	ISO 3745
Sound Power Level(Indoor Unit)	Cooling ((SH)/H/M/L)	dB(A)	-
	Heating ((SH)/H/M/L)	dB(A)	-
Measurement Standard (Power Level)	-	-	-
Connecting Cable	Power and Communication cable(H07RN-F)	mm² × cores	0.75 x 4

5. ATNW60GMLP1

Category		Unit	Specification
Major	Minor		
Power Supply Type to Indoor	-	-	-
Electrical Characteristic	Maximum Fuse Amperes (MFA)	A	40
	Indoor Fan Motor_Full Load Amperes (FLA / Max)	A	0.8

Note

- Due to our policy of innovation some specifications may be changed without notification.
- Wiring cable size must comply with the applicable local and national code.
And "Electric characteristics" should be considered for electrical work and design.
- Especially the power cable and circuit breaker should be selected in accordance with that.
- Sound Level Values are measured at Noise Measuring chamber accordance with standard.
Therefore, these values depend on the ambient conditions and values are normally higher in actual operation.

5. ATNW60GMLP1

5.2 List of Functions

Category	Functions	Availability
Air Flow	Air Supply Outlet	4
	Airflow Direction Control (left & right)	X
	Airflow Direction Control (up & down)	Auto
	Auto Swing (left & right)	X
	Auto Swing (up & down)	O
	Airflow Steps (fan/cool/heat)	4 / 5 / 4
	Fan Speed Auto*	X
	Power Cool/Heat	O / X
	Swirl Wind*	O
	Refresh Mode**	X
	Smart Mode**	X
	Indirect Wind*	O
	Direct Wind*	O
	Dry Operation	O
Air Purification	Air Purify	Accessory
	Ionizer	X
	UV-C	X
	Allergy Filter	X
	Pre-Filter	O
	PM1.0 Filter	X
Reliability	Hot Start	O
	Self Diagnosis	O
Convenience	Auto Mode	O
	Auto Dry Operation**	X
	Auto Restart	O
	Child Lock*	O
	Forced Operation	O
	Group Control*	O
	Sleep Timer**	O
	Turn On/Off Reservation**	O
	Schedule**	O
	Two Thermistor Control*	O
	Time Limit Control (Energy saving)***	O
External On/Off	O	
Installation	Drain Pump	O
	High Ceiling Operation*	O
Special Functions	Wi-Fi Control	Accessory
	Comfort Cooling (Humidity Control)***	O
	Auto Elevation Grille	Accessory(PTEGM0)
	Human Detection Function***	Accessory
	Floor Detection Function***	X

Note

- O : Applied, X : Not Applied, - : Unconfirmed or irrelevant
- Embedded : A kit is provided by default for using this function when the product is manufactured.
- Accessory : Ordered and purchased separately the accessory package referring to the model name provided and install at field.
- Accessory line-ups varies by region, so check your local catalogue or local sales material.
- Some functions can be limited by remote controller.
- In case of cassette type indoor units, Plasma kit and Auto Elevation Grille functions are not applicable at the same time.
- 'Auto Mode' varies depending on the outdoor unit type.
 - Auto Change Over(Single Heat Pump Outdoor Unit)
 - Auto Mode Select(Multi Heat Pump Outdoor Unit)

5. ATNW60GMLP1

- Auto Intensity Control(Cooling Only Outdoor Unit)
- * : These functions need to connect the wired remote controller.
- ** : This functions need to connect to the Standard II / III wired remote controller.
- *** : This functions need to connect to the Standard III wired remote controller.

5. ATNW60GMLP1

5.3 Accessory Compatibility List

Category	Accessory Name	Model Name	Description	Compatibility
Remote Controller	Wired - Premium	PREMTA000	-	O
		PREMTA000A	-	O
		PREMTA000B	-	O
	Wired - RS3 (Standard III)	PREMTB100	White	O
		PREMTBB10	Black	O
	Wired - RS2 (Standard II)	PREMTB001	White	O
		PREMTBB01	Black	O
	Wired - Simple	PQRCVCL0QW	White	O
		PQRCVCL0Q	Black	O
	Wired - Simple for hotel	PQRCHCA0QW	White	O
		PQRCHCA0Q	Black	O
	Wireless	PQWRQC0FDB	For Cooling only	O
		PQWRHQ0FDB	For Heat pump	O
		PWLSSB21C	For Cooling only	O
PWLSSB21H		For Heat pump	O	
Dry Contact	Simple	PDRYCB000	1 input port, AC 220 - 240V	O
		PDRYCB100	1 input port, AC 24V	O
	Communication	PDRYCB400	2 input port	O
		PDRYCB300	8 input port, For 3rd party Thermostat	O
		PDRYCB320	8 input port, For 3rd Party Thermostat (Analog Input)	O
PDRYCB500	For 3rd Party Controller(Modbus RTU)	O		
Integration Device	Remote Temperature sensor	PQRSTA0	-	O
	Group Control wire	PZCWRCG3	Cable Assembly for group control (Y-type cable : 0.25m, cable : 9.6m)	O
ETC	Extension wire	PZCWRC1	Extension wire for IDU-wired remote controller (9.6m)	O
	2-Remo Control wire	PZCWRC2	-	X
	Wi-Fi Modem	PWFMD200	-	O
	Wi-Fi Extension cable	PWYREW000	USB Extension cable : 10 m	O
	Independent Power Module	PRIP0	For Multi V Indoor Unit	X
	Multi-tenant Power module	PINPMB001	For Multi V Indoor Unit	X
	Refrigerant Leakage Detector	PRLDNVS0	For Multi V Indoor Unit (R410A)	X
	Human Detection Sensor	PTVSMA0	For Cassette 4-way	O
		PTVSAA0	For Cassette Dual Vane 4-way	X
	Floor Detection Sensor	PTFSMA0	For Cassette Dual Vane 4-way	X
	Auto Elevation Grille	PTEGM0	For Cassette 4-way	X
	Air Purification Kit	PTAHTP0	For Cassette 1-way	X
		PTAHMP0	For Cassette 4-way	O
		PTAHYP0	For Cassette Round	X
	EEV Kit	PRGK024A0	For Multi V Indoor Unit	X
	Auxiliary Heater Relay Kit	PRARS1	For Wall Mounted / Art Cool Indoor Units	X
		PRARH1	For Cassette / Duct Indoor Units	X
	Ventilation Kit	PTVK430	For TR/TQ/TP/TN/TM Chassis	X
		PTVK410 / PTVK420	For TP/TN/TM Chassis	X
	Cassette Cover	PTDCQ	For TR/TQ Chassis	X
PTDCM		For TP/TN/TM Chassis	X	
PTDCA		For TM-A/TP-B Chassis	X	

Note

- O: Possible, X: Impossible, -: Unconfirmed or irrelevant.
- *: Some advanced functions controlled by individual controller cannot be operated.
- Air Purification Kit and Auto Elevation Grille are not applicable at the same time.
- If there is a difference in development time between the product and the remote controller, some functions cannot be operated.
- If you need more detail, please refer to the Control(BECON) PDB or the manual of product.
(<http://partner.lge.com/global> : Home> Doc.Library> Product > Control(BECON)).

5. ATNW60GMLP1

5.4 Dimensions

5.4.1 Product

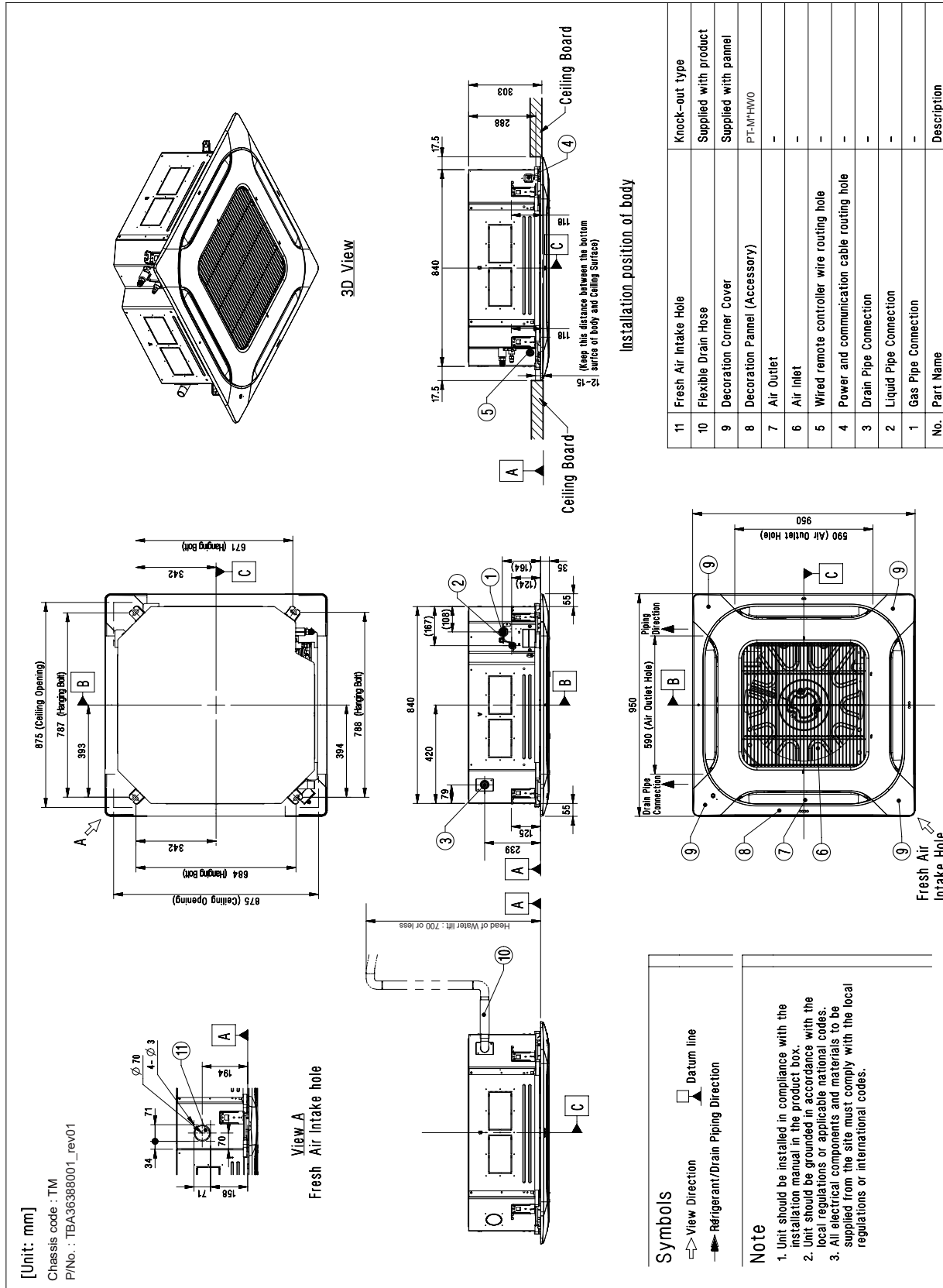

5. ATNW60GMLP1

5.4.2 Install Space

< Minimum Installation Space >

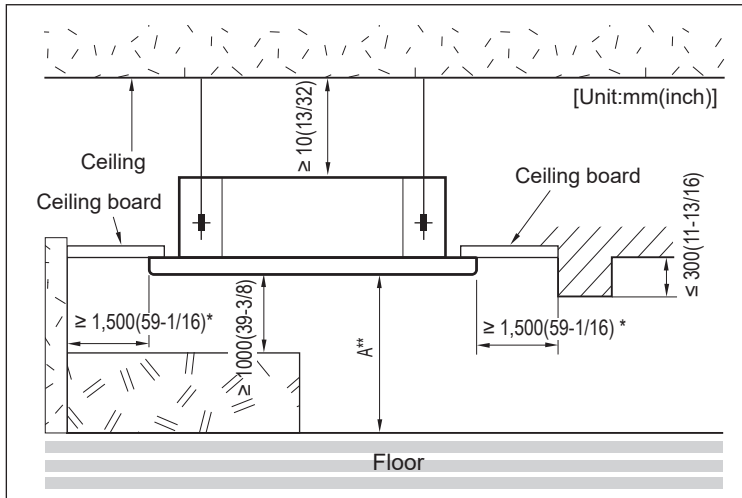

Notes

1. *: Minimum Installation Space to Air flow direction
A separation distance of at least 1,500 mm is required throughout the airflow direction.

2. **: A, Installation Height from the floor

Capacity Class	Installation Height (A)		
	Min.	Standard ***	Max.
< 10 kW	2.0 m (6.56 ft)	2.7 m (8.86 ft)	3.6 m (11.81 ft)
≥ 10 kW	2.5 m (8.20 ft)	3.2 m (10.50 ft)	4.2 m (13.78 ft)

*** : Standard Height (Recommended)

If it exceeds the standard height, set the 'High Ceiling Mode'.

For details about function setting, refer to the installation manual.

< Cautions for Panel installation >

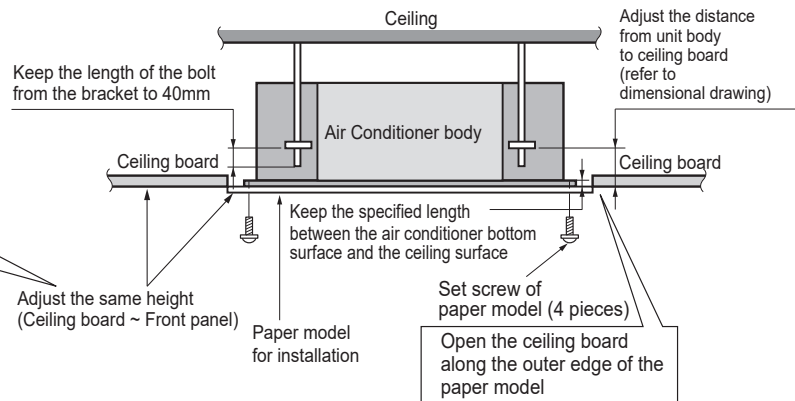
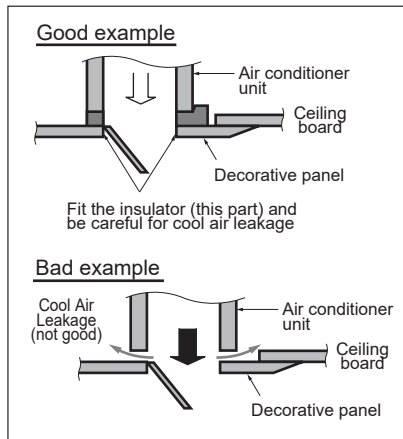

< Series installation >

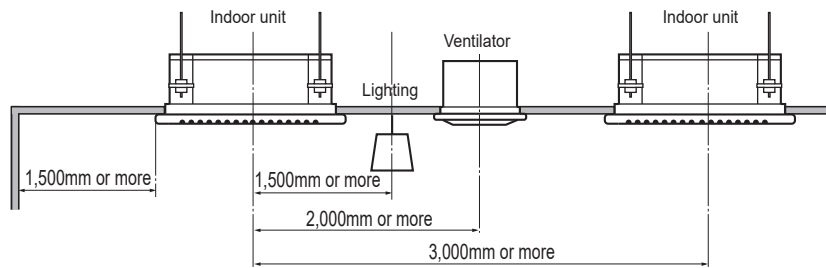

※ According to type of indoor unit, external appearance could be different.

Note

- Places where products are installed should not be any obstacles to the air circulation or installation. Ensure the spaces from the wall, ceiling, or other obstacles.
- According to type of indoor unit, external appearance or installed structure could be different.
- According to product type, model line up, sales region..etc, applicability of each chassis could be different.
- Install certainly the decoration panel. Cool air leakage causes sweating or falling of water-drops.

5. ATNW60GMLP1

5.5 Piping Diagrams

5.5.1 Normal

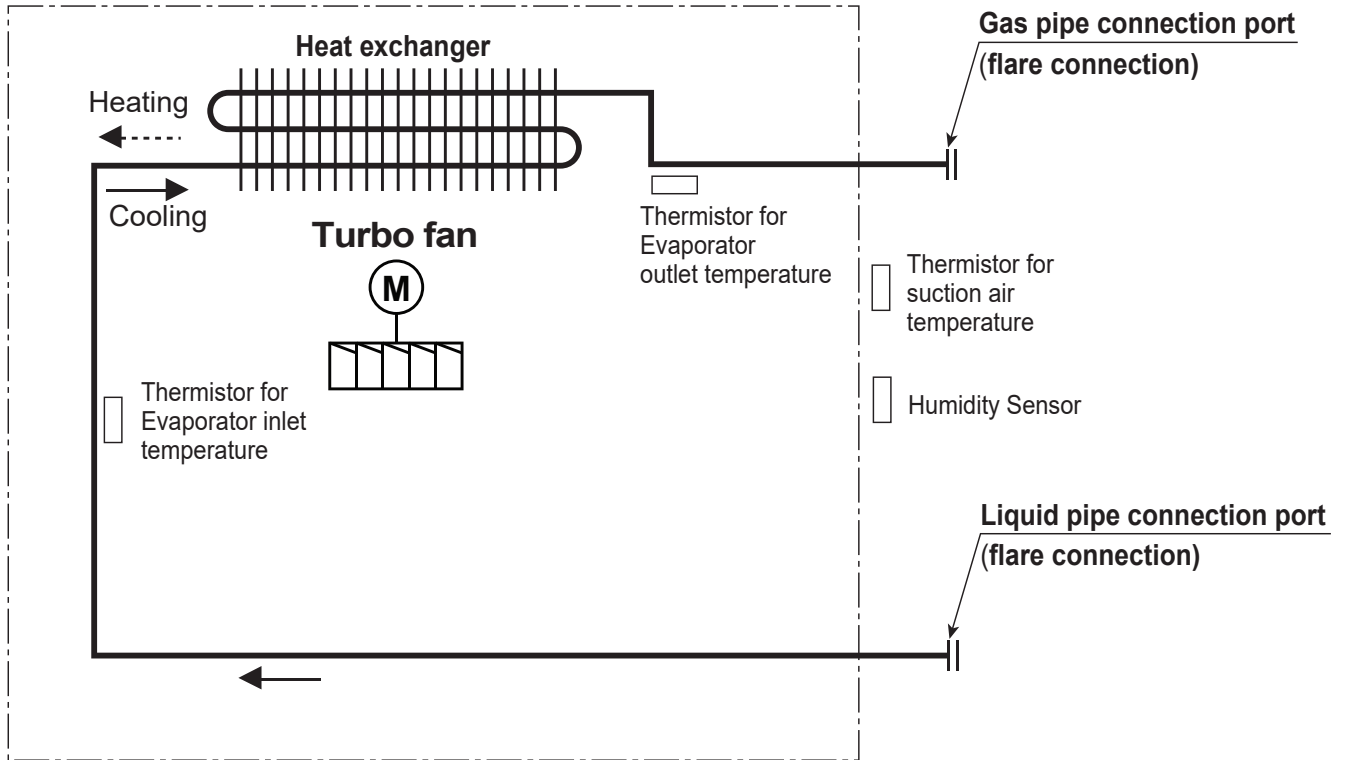

5. ATNW60GMLP1

5.6 Wiring Diagrams

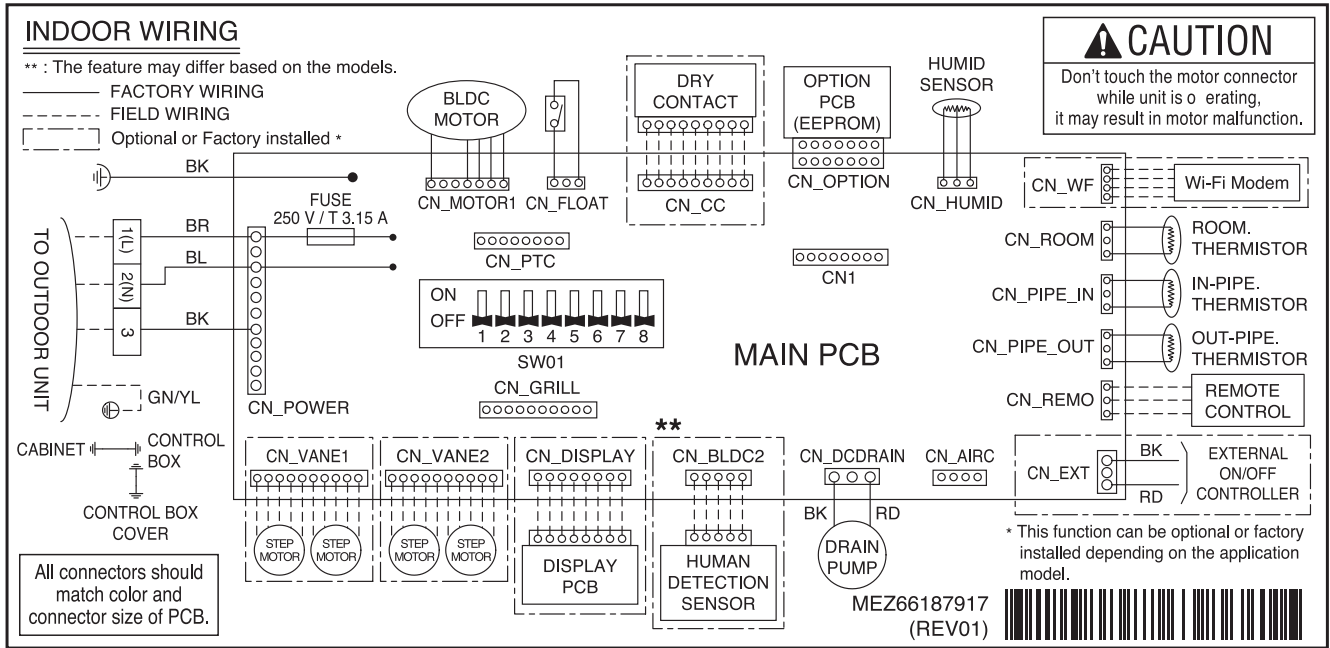

5. ATNW60GMLP1

5.7 Sound Levels

5.7.1 Pressure Levels

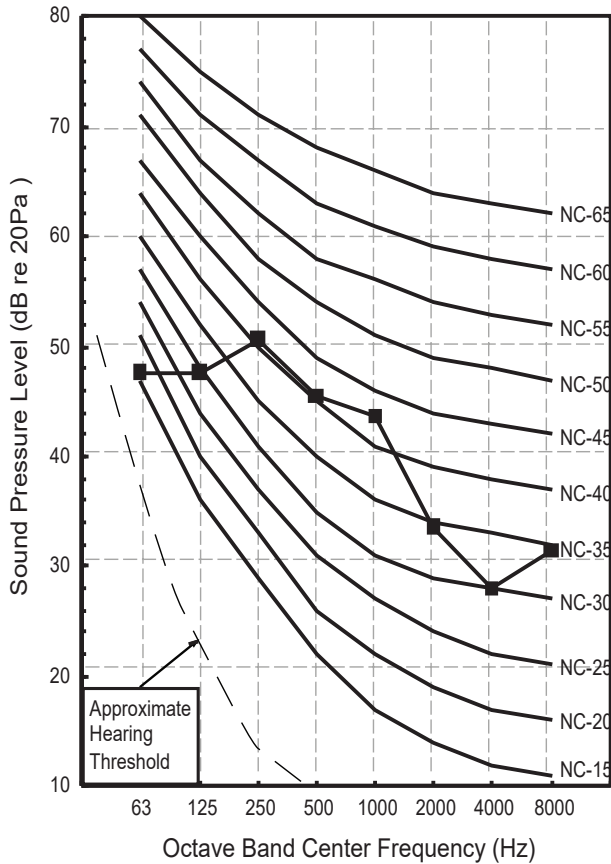

Sound level [dB(A), @ Standard condition]	
Cooling ((SH)/H/M/L)	- / 47.0 / 45.0 / 42.0
Heating ((SH)/H/M/L)	- / 47.0 / 45.0 / 42.0

Note

- Sound measured at some distance away from the center of the unit.
- Data is valid at free field condition.
- Reference acoustic pressure 0dB = 20μPa.
- Data is valid at nominal operation condition.
Refer to the Model Specifications for nominal conditions(Power source and Ambient temperature, etc)
- Sound levels can be increased in accordance with installation and operating conditions.
(Static pressure mode, used air guide, Room target temperature setting, etc)
- Sound pressure level is measured on the rated condition in the anechoic rooms by ISO 3745 standard.
Therefore, these values can be increased owing to ambient conditions during operation.

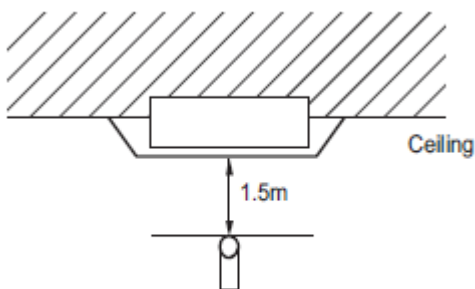

* Measuring place : Anechoic chamber

5. ATNW60GMLP1

5.8 Air flow and temperature distributions

5.8.1 Cooling

Cooling

Discharge angle: 40°

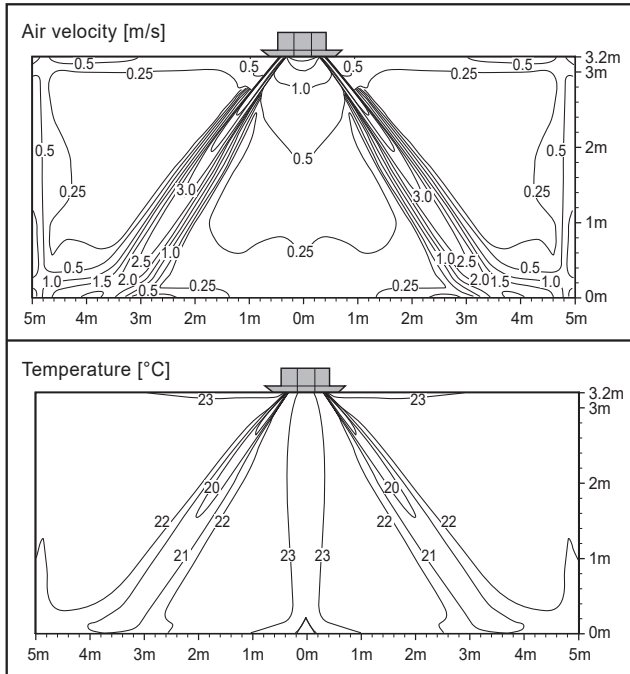

Note

- These figures are accordance with normal certain condition and environment.
(Airflow step is 'High', Air discharge angle is fixed as indicated angle.)
- Indoor airflow distribution under actual installation or operating conditions depends on ambient temperature, ceiling height, product installation direction / location, indoor / Heating load, and other obstacles, etc.

5. ATNW60GMLP1

5.8.2 Heating

Discharge angle: 50°

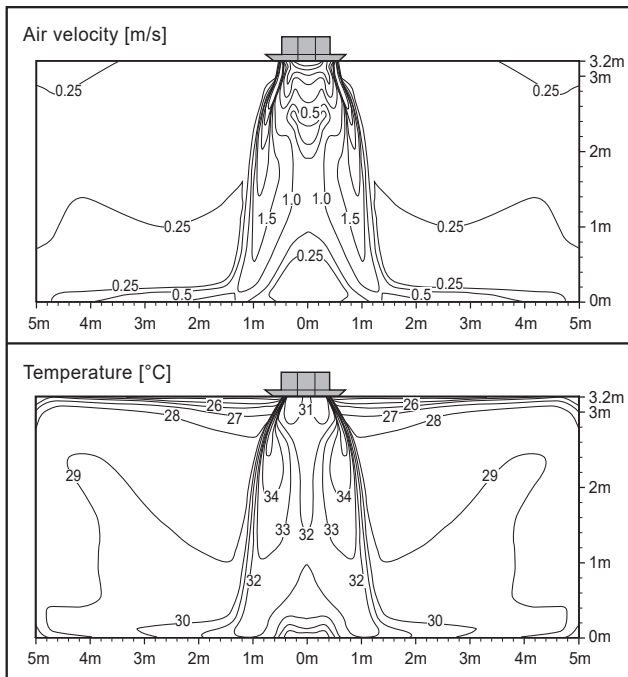

Note

- These figures are accordance with normal certain condition and environment.
(Airflow step is 'High', Air discharge angle is fixed as indicated angle.)
- Indoor airflow distribution under actual installation or operating conditions depends on ambient temperature, ceiling height, product installation direction / location, indoor / Heating load, and other obstacles, etc.

1. AVNW36GM1P1

1.1 Specifications

Category		Unit	Specification
Major	Minor		
Classification	Chassis	-	VM1
Power Supply	Case 1	-	220, 1, 60
	Case 2	-	-
	Limit Range of Voltage(Case 1)	V	198~242
	Limit Range of Voltage(Case 2)	V	-
Cooling Capacity	Nominal	kW	8.79
		Btu/h	30,000
Heating Capacity	Nominal	kW	9.97
		Btu/h	34,000
Power Input(Indoor)	H/M/L	W	-
Running Current	H/M/L	A	-
Indoor Fan	Type	-	CFF
	Quantity	EA	1
	Air Flow Rate((SH)/H/M/L)	m³/min	- / 20.0 / 18.0 / 16.0
	Air Flow Rate Range(Min~Max)	m³/min	16.0~20.0
	External Static Pressure_Factory Set	Pa	-
Indoor Fan Motor	Type	-	BLDC
	Drive	-	-
	Output	W	85.9
		No.	1
Dehumidification Rate	-	ℓ/h	3.80
Heat Exchanger	Rows x Columns x FPI	-	3 x 18 x 18
	No.	-	1
	Fin Type	-	Louver
	Face Area	m²	0.31
Dimensions	Net(W x H x D)	mm	1,200 x 235 x 690
	Shipping(W x H x D)	mm	1,315 x 317 x 768
Weight	Net	kg	28.4
	Shipping	kg	34.3
Exterior	Color	-	Morning Fog
	RAL (Classic)	-	RAL 9001
Air Filter	Type	-	Long Life
Protection Device	Fuse	-	O
	Overload Protector for Fan Motor	-	Thermal Protector for Fan Motor
Refrigerant	Type	-	R410A
	Control Type	-	-
Drain Pipe(Natural Drainage)	O.D / I.D	mm(inch)	21.5 / 16.0
Drain Pipe(using Drain Pump)	O.D / I.D	mm(inch)	-
Pipe Connecting Socket	Liquid	mm(inch)	Φ9.52 (3/8)
	Gas	mm(inch)	Φ15.88 (5/8)
	Connection Type(Liquid)	-	Flare
	Connection Type(Gas)	-	Flare
Sound Pressure Level(Indoor Unit)	Cooling ((SH)/H/M/L)	dB(A)	- / 47.0 / 45.0 / 42.0
	Heating ((SH)/H/M/L)	dB(A)	- / 47.0 / 45.0 / 42.0
Measurement Standard (Pressure Level)	-	-	ISO 3745
Sound Power Level(Indoor Unit)	Cooling ((SH)/H/M/L)	dB(A)	-
	Heating ((SH)/H/M/L)	dB(A)	-
Measurement Standard (Power Level)	-	-	-
Connecting Cable	Power and Communication cable(H07RN-F)	mm² × cores	0.75 x 4

1. AVNW36GM1P1

Category		Unit	Specification
Major	Minor		
Power Supply Type to Indoor	-	-	-
Electrical Characteristic	Maximum Fuse Amperes (MFA)	A	25
	Indoor Fan Motor_Full Load Amperes (FLA / Max)	A	0.5

Note

- Due to our policy of innovation some specifications may be changed without notification.
- Wiring cable size must comply with the applicable local and national code.
And "Electric characteristics" should be considered for electrical work and design.
- Especially the power cable and circuit breaker should be selected in accordance with that.
- Sound Level Values are measured at Noise Measuring chamber accordance with standard.
Therefore, these values depend on the ambient conditions and values are normally higher in actual operation.

1. AVNW36GM1P1

1.2 List of Functions

Category	Functions	Availability
Air Flow	Air Supply Outlet	1
	Airflow Direction Control (left & right)	X
	Airflow Direction Control (up & down)	Auto
	Auto Swing (left & right)	X
	Auto Swing (up & down)	O
	Airflow Steps (fan/cool/heat)	4 / 5 / 5
	Fan Speed Auto*	O
	Power Cool/Heat	O / O
	Swirl Wind*	X
	Refresh Mode**	X
	Smart Mode**	X
	Indirect Wind*	O
	Direct Wind*	O
	Dry Operation	O
Air Purification	Air Purify	X
	Ionizer	X
	UV-C	X
	Allergy Filter	X
	Pre-Filter	O
	PM1.0 Filter	X
Reliability	Hot Start	O
	Self Diagnosis	O
Convenience	Auto Mode	O
	Auto Dry Operation**	O
	Auto Restart	O
	Child Lock*	O
	Forced Operation	X
	Group Control*	O
	Sleep Timer**	O
	Turn On/Off Reservation**	O
	Schedule**	O
	Two Thermistor Control*	O
	Time Limit Control (Energy saving)***	O
External On/Off	O	
Installation	Drain Pump	X
	High Ceiling Operation*	X
Special Functions	Wi-Fi Control	Accessory
	Comfort Cooling (Humidity Control)***	O
	Auto Elevation Grille	X
	Human Detection Function***	X
	Floor Detection Function***	X

Note

- O : Applied, X : Not Applied, - : Unconfirmed or irrelevant
- Embedded : A kit is provided by default for using this function when the product is manufactured.
- Accessory : Ordered and purchased separately the accessory package referring to the model name provided and install at field.
- Accessory line-ups varies by region, so check your local catalogue or local sales material.
- Some functions can be limited by remote controller.
- In case of cassette type indoor units, Plasma kit and Auto Elevation Grille functions are not applicable at the same time.
- 'Auto Mode' varies depending on the outdoor unit type.
 - Auto Change Over(Single Heat Pump Outdoor Unit)
 - Auto Mode Select(Multi Heat Pump Outdoor Unit)

1. AVNW36GM1P1

- Auto Intensity Control(Cooling Only Outdoor Unit)
- * : These functions need to connect the wired remote controller.
- ** : This functions need to connect to the Standard II / III wired remote controller.
- *** : This functions need to connect to the Standard III wired remote controller.

1. AVNW36GM1P1

1.3 Accessory Compatibility List

Category	Accessory Name	Model Name	Description	Compatibility
Remote Controller	Wired - Premium	PREMTA000	-	O
		PREMTA000A	-	O
		PREMTA000B	-	O
	Wired - RS3 (Standard III)	PREMTB100	White	X
		PREMTBB10	Black	X
	Wired - RS2 (Standard II)	PREMTB001	White	X
		PREMTBB01	Black	X
	Wired - Simple	PQRCVCL0QW	White	X
		PQRCVCL0Q	Black	X
	Wired - Simple for hotel	PQRCHCA0QW	White	X
		PQRCHCA0Q	Black	X
	Wireless	PQWRQC0FDB	For Cooling only	O
		PQWRHQ0FDB	For Heat pump	O
		PWLSSB21C	For Cooling only	O
		PWLSSB21H	For Heat pump	O
Dry Contact	Simple	PDRYCB000	1 input port, AC 220 - 240V	O
		PDRYCB100	1 input port, AC 24V	O
	Communication	PDRYCB400	2 input port	O
		PDRYCB300	8 input port, For 3rd party Thermostat	O
		PDRYCB320	8 input port, For 3rd Party Thermostat (Analog Input)	O
PDRYCB500	For 3rd Party Controller(Modbus RTU)	O		
Integration Device	Remote Temperature sensor	PQRSTA0	-	O
	Group Control wire	PZCWRCG3	Cable Assembly for group control (Y-type cable : 0.25m, cable : 9.6m)	O
ETC	Extension wire	PZCWRC1	Extension wire for IDU-wired remote controller (9.6m)	O
	2-Remo Control wire	PZCWRC2	-	X
	Wi-Fi Modem	PWFMD200	-	O
	Wi-Fi Extension cable	PWYREW000	USB Extension cable : 10 m	O
	Independent Power Module	PRIP0	For Multi V Indoor Unit	X
	Multi-tenant Power module	PINPMB001	For Multi V Indoor Unit	X
	Refrigerant Leakage Detector	PRLDNVS0	For Multi V Indoor Unit (R410A)	X
	Human Detection Sensor	PTVSMA0	For Cassette 4-way	X
		PTVSAA0	For Cassette Dual Vane 4-way	X
	Floor Detection Sensor	PTFSMA0	For Cassette Dual Vane 4-way	X
	Auto Elevation Grille	PTEGM0	For Cassette 4-way	X
	Air Purification Kit	PTAHTP0	For Cassette 1-way	X
		PTAHMP0	For Cassette 4-way	X
		PTAHYP0	For Cassette Round	X
	EEV Kit	PRGK024A0	For Multi V Indoor Unit	X
	Auxiliary Heater Relay Kit	PRARS1	For Wall Mounted / Art Cool Indoor Units	O
		PRARH1	For Cassette / Duct Indoor Units	O
	Ventilation Kit	PTVK430	For TR/TQ/TP/TN/TM Chassis	X
		PTVK410 / PTVK420	For TP/TN/TM Chassis	X
	Cassette Cover	PTDCQ	For TR/TQ Chassis	X
		PTDCM	For TP/TN/TM Chassis	X
PTDCA		For TM-A/TP-B Chassis	X	

Note

- O: Possible, X: Impossible, -: Unconfirmed or irrelevant.
- *: Some advanced functions controlled by individual controller cannot be operated.
- Air Purification Kit and Auto Elevation Grille are not applicable at the same time.
- If there is a difference in development time between the product and the remote controller, some functions cannot be operated.
- If you need more detail, please refer to the Control(BECON) PDB or the manual of product.
(<http://partner.lge.com/global> : Home> Doc.Library> Product > Control(BECON)).

1. AVNW36GM1P1

1.4 Dimensions

1.4.1 Product

[Unit: mm]
Chassis code : VM1
DWG No. : TAZ35326401_Rev01

Front View Dimensions:
 Total width: 1018 mm
 Distance from left edge to center: 509 mm
 Distance from right edge to center: 509 mm
 Distance from left edge to hanging hole: 356 mm
 Distance from right edge to hanging hole: 356 mm
 Hanging hole diameter: 82 mm
 Total height: 987 mm
 Distance from top edge to center: 216 mm
 Distance from bottom edge to center: 216 mm

Side View Dimensions:
 Total depth: 1200 mm
 Distance from front edge to center: 600 mm
 Distance from back edge to center: 600 mm
 Air outlet hole diameter: 132 mm
 Air intake hole diameter: 833 mm

Section A-A Dimensions:
 Total width: 690 mm
 Distance from left edge to center: 345 mm
 Distance from right edge to center: 345 mm
 Air intake hole diameter: 833 mm
 Air outlet hole diameter: 132 mm

Section View Dimensions:
 Section view 1: 235 mm
 Section view 2: 188 mm
 Section view 3: 37 mm
 Section view 4: 61 mm
 Section view 5: 110 mm
 Section view 6: 15 mm

Note

- Unit should be installed in compliance with the installation manual in the product box.
- Unit should be grounded in accordance with the local regulations or applicable national codes.
- All electrical components and materials to be supplied from the site must comply with the local regulations or international codes.

No.	Part Name	Description
7	Liquid pipe connection	-
6	Gas pipe connection	-
5	Refrigerant pipe and cable routing hole	Knock-out type
4	Drain hose routing hole	Knock-out type
3	Remote Controller Signal Receiver	For wireless type
2	Air outlet	-
1	Air intake	-

1. AVNW36GM1P1

1.4.2 Installation Space

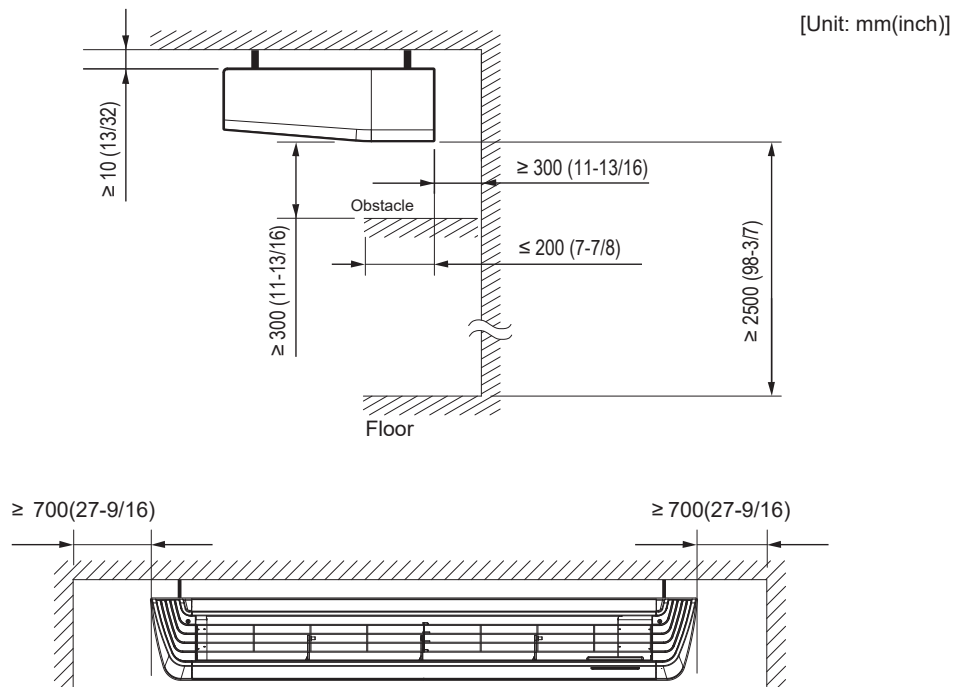
**Note**

- Places where products are installed should not be any obstacles to the air circulation or installation. Ensure the spaces from the wall, ceiling, or other obstacles.
- According to type of indoor unit, external appearance or installed structure could be different.
- According to product type, model line up, sales region..etc, applicability of each chassis could be different.

1. AVNW36GM1P1

1.5 Piping Diagrams

1.5.1 Normal

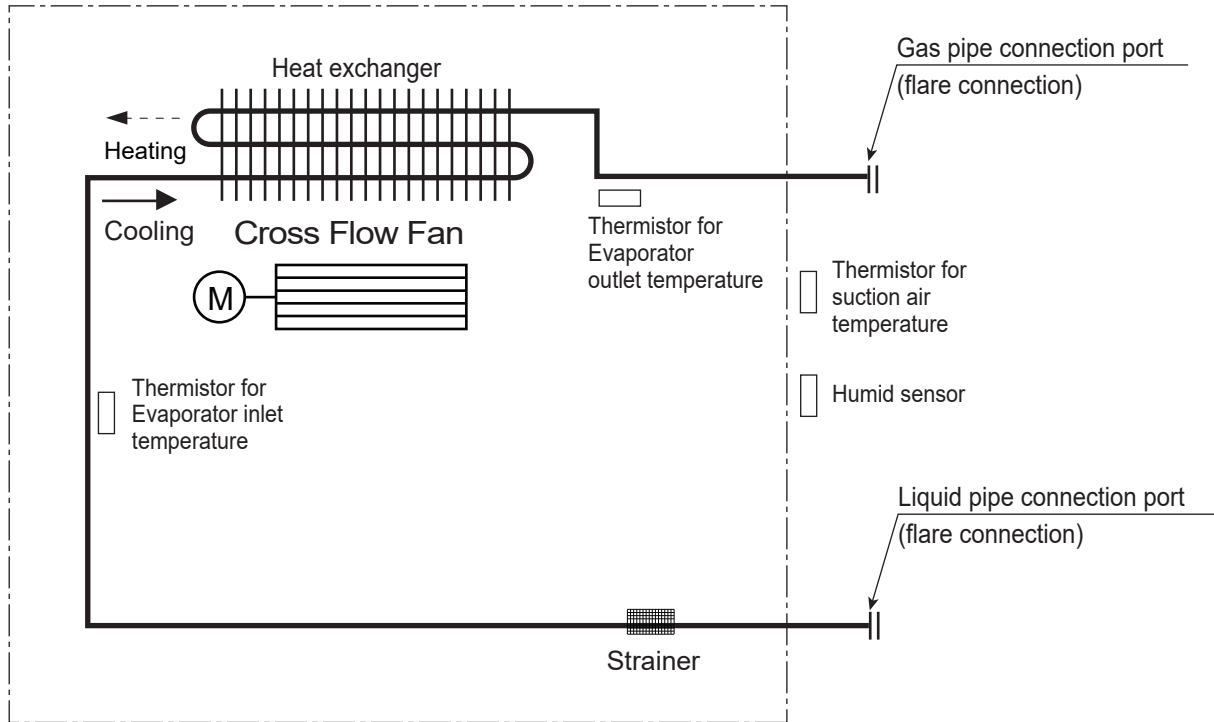

1. AVNW36GM1P1

1.6 Wiring Diagrams

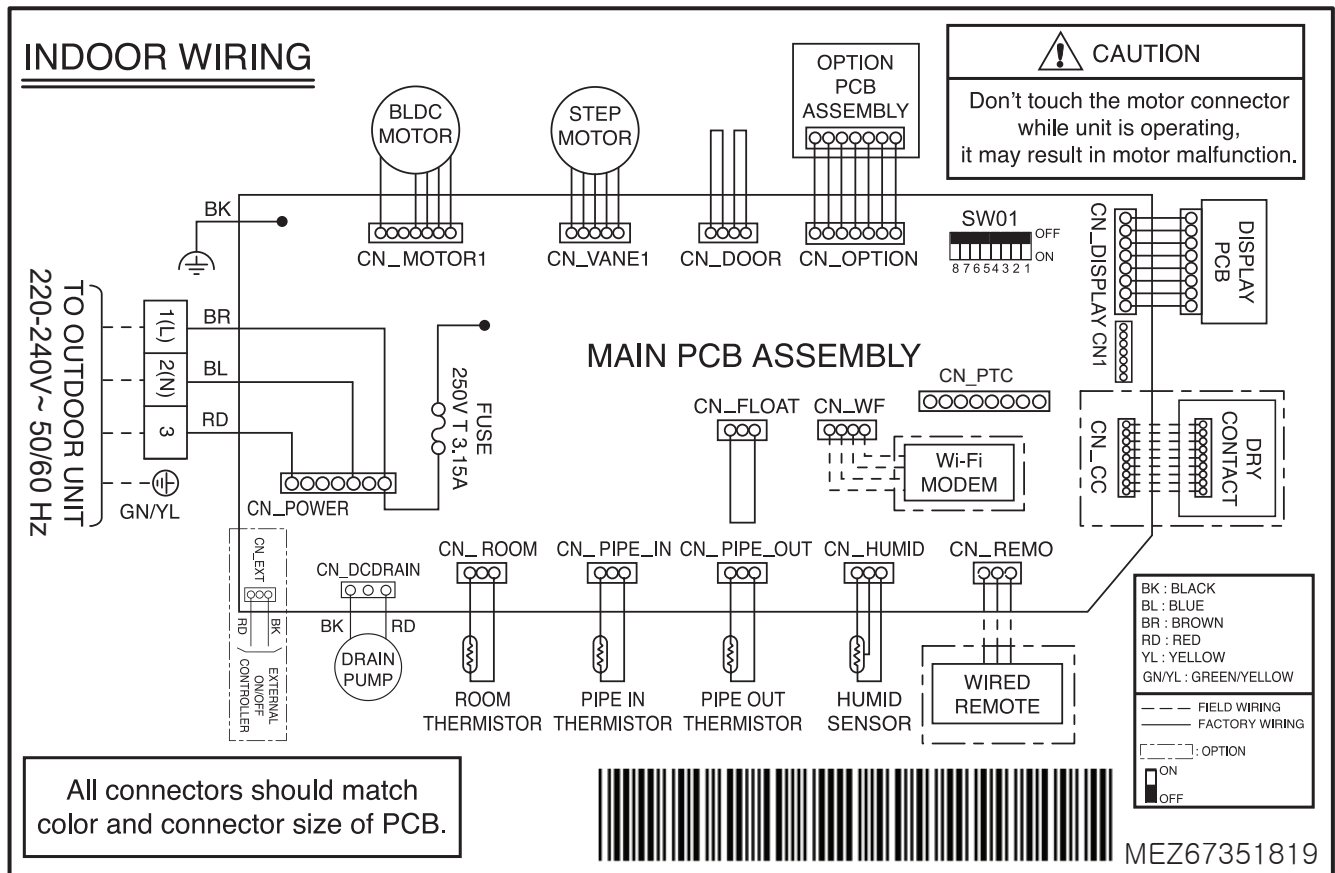

1. AVNW36GM1P1

1.7 Sound Levels

1.7.1 Pressure Levels

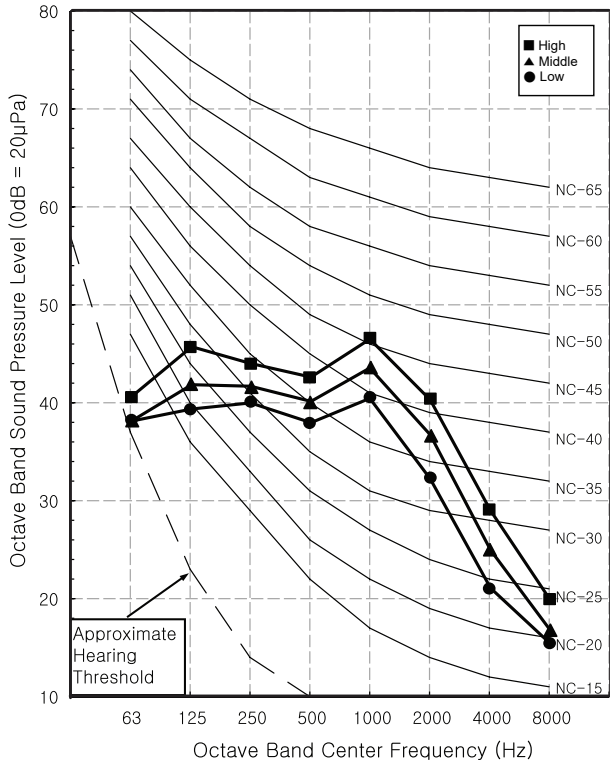

Sound level [dB(A), @ Standard condition]	
Cooling ((SH)/H/M/L)	- / 47.0 / 45.0 / 42.0
Heating ((SH)/H/M/L)	- / 47.0 / 45.0 / 42.0

Note

- Sound measured at some distance away from the center of the unit.
- Data is valid at free field condition.
- Reference acoustic pressure 0dB = 20µPa.
- Data is valid at nominal operation condition.
Refer to the Model Specifications for nominal conditions(Power source and Ambient temperature, etc)
- Sound levels can be increased in accordance with installation and operating conditions.
(Static pressure mode, used air guide, Room target temperature setting, etc)
- Sound pressure level is measured on the rated condition in the anechoic rooms by ISO 3745 standard.
Therefore, these values can be increased owing to ambient conditions during operation.

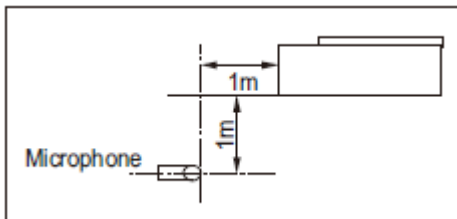

1. AVNW36GM1P1

1.8 Air flow and temperature distributions

1.8.1 Cooling operation

Discharge angle: 0°

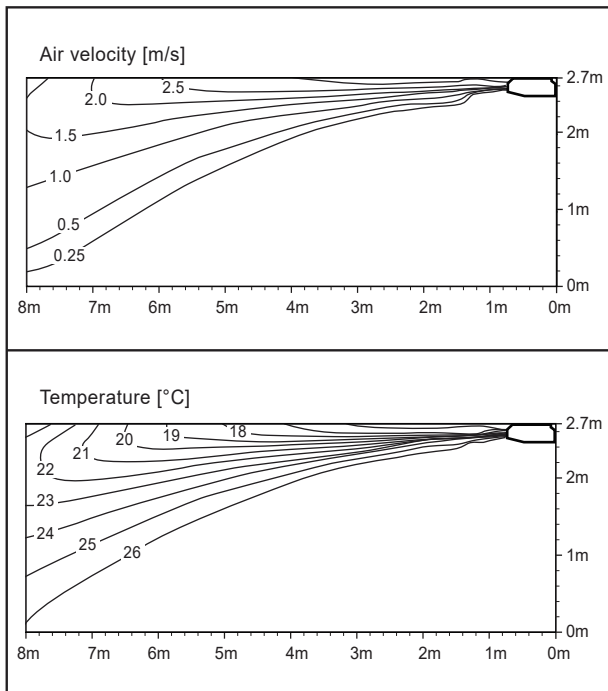

Note

- These figures are accordance with normal certain condition and environment.
(Airflow step is 'High', Air discharge angle is fixed as indicated angle.)
- Indoor airflow distribution under actual installation or operating conditions depends on ambient temperature, ceiling height, product installation direction / location, indoor / Heating load, and other obstacles, etc.

1. AVNW36GM1P1

1.8.2 Heating operation

Discharge angle: 0°

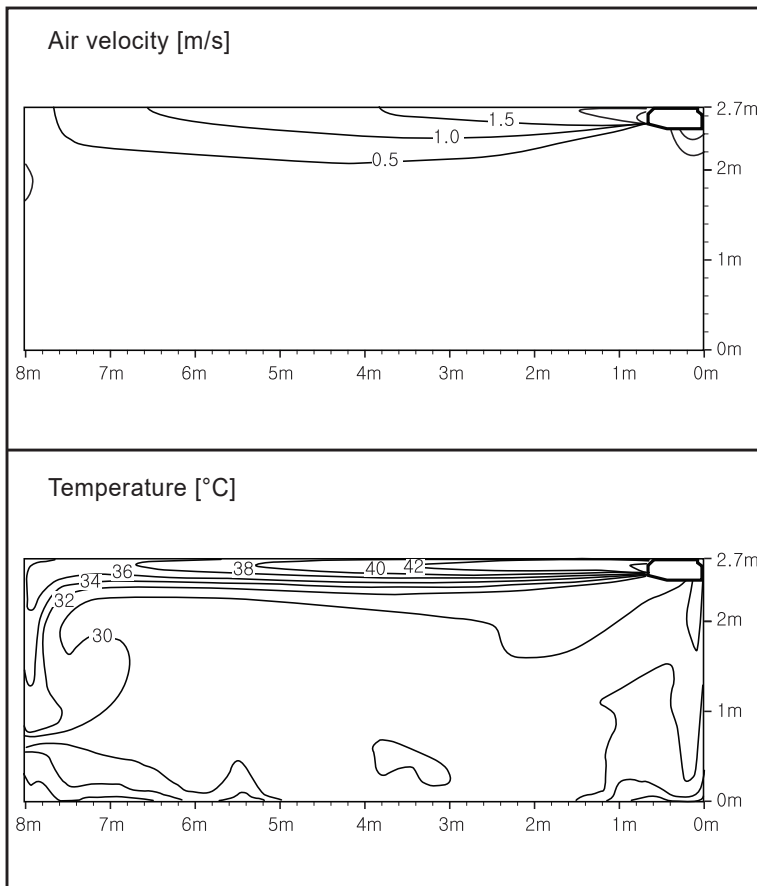

Note

- These figures are accordance with normal certain condition and environment.
(Airflow step is 'High', Air discharge angle is fixed as indicated angle.)
- Indoor airflow distribution under actual installation or operating conditions depends on ambient temperature, ceiling height, product installation direction / location, indoor / Heating load, and other obstacles, etc.

2. AVNW48GM2P1

2.1 Specifications

Category		Unit	Specification
Major	Minor		
Classification	Chassis	-	VM2
Power Supply	Case 1	-	220-230-240, 1, 50
	Case 2	-	-
	Limit Range of Voltage(Case 1)	V	198~242
	Limit Range of Voltage(Case 2)	V	-
Cooling Capacity	Nominal	kW	13.78
		Btu/h	47,000
Heating Capacity	Nominal	kW	15.53
		Btu/h	53,000
Power Input(Indoor)	H/M/L	W	-
Running Current	H/M/L	A	-
Indoor Fan	Type	-	CFF
	Quantity	EA	2
	Air Flow Rate((SH)/H/M/L)	m³/min	- / 30.0 / 25.0 / 20.0
	Air Flow Rate Range(Min~Max)	m³/min	20.0~30.0
	External Static Pressure_Factory Set	Pa	-
Indoor Fan Motor	Type	-	BLDC
	Drive	-	-
	Output	W	125
		No.	1
Dehumidification Rate	-	ℓ/h	6.50
Heat Exchanger	Rows x Columns x FPI	-	3 x 18 x 18
	No.	-	1
	Fin Type	-	Louver
	Face Area	m²	0.46
Dimensions	Net(W x H x D)	mm	1,600 x 235 x 690
	Shipping(W x H x D)	mm	1,715 x 317 x 768
Weight	Net	kg	36.9
	Shipping	kg	45.5
Exterior	Color	-	Morning Fog
	RAL (Classic)	-	RAL 9001
Air Filter	Type	-	Long Life
Protection Device	Fuse	-	O
	Overload Protector for Fan Motor	-	Thermal Protector for Fan Motor
Refrigerant	Type	-	R410A
	Control Type	-	-
Drain Pipe(Natural Drainage)	O.D / I.D	mm(inch)	21.5 / 16.0
Drain Pipe(using Drain Pump)	O.D / I.D	mm(inch)	-
Pipe Connecting Socket	Liquid	mm(inch)	Φ9.52 (3/8)
	Gas	mm(inch)	Φ19.05 (3/4)
	Connection Type(Liquid)	-	Flare
	Connection Type(Gas)	-	Flare
Sound Pressure Level(Indoor Unit)	Cooling ((SH)/H/M/L)	dB(A)	- / 50.0 / 46.0 / 42.0
	Heating ((SH)/H/M/L)	dB(A)	- / 50.0 / 46.0 / 42.0
Measurement Standard (Pressure Level)	-	-	ISO 3745
Sound Power Level(Indoor Unit)	Cooling ((SH)/H/M/L)	dB(A)	-
	Heating ((SH)/H/M/L)	dB(A)	-
Measurement Standard (Power Level)	-	-	-
Connecting Cable	Power and Communication cable(H07RN-F)	mm² × cores	0.75 x 4

2. AVNW48GM2P1

Category		Unit	Specification
Major	Minor		
Power Supply Type to Indoor	-	-	-
Electrical Characteristic	Indoor Fan Motor_Full Load Amperes (FLA)	A	0.6

Note

- Due to our policy of innovation some specifications may be changed without notification.
- Wiring cable size must comply with the applicable local and national code.
And "Electric characteristics" should be considered for electrical work and design.
- Especially the power cable and circuit breaker should be selected in accordance with that.
- Sound Level Values are measured at Noise Measuring chamber accordance with standard.
Therefore, these values depend on the ambient conditions and values are normally higher in actual operation.

2. AVNW48GM2P1

2.2 List of Functions

Category	Functions	Availability
Air Flow	Air Supply Outlet	1
	Airflow Direction Control (left & right)	X
	Airflow Direction Control (up & down)	Auto
	Auto Swing (left & right)	X
	Auto Swing (up & down)	O
	Airflow Steps (fan/cool/heat)	4 / 5 / 5
	Fan Speed Auto*	O
	Power Cool/Heat	O / O
	Swirl Wind*	X
	Refresh Mode**	X
	Smart Mode**	X
	Indirect Wind*	O
	Direct Wind*	O
	Dry Operation	O
Air Purification	Air Purify	X
	Ionizer	X
	UV-C	X
	Allergy Filter	X
	Pre-Filter	O
	PM1.0 Filter	X
Reliability	Hot Start	O
	Self Diagnosis	O
Convenience	Auto Mode	O
	Auto Dry Operation**	O
	Auto Restart	O
	Child Lock*	O
	Forced Operation	X
	Group Control*	O
	Sleep Timer**	O
	Turn On/Off Reservation**	O
	Schedule**	O
	Two Thermistor Control*	O
	Time Limit Control (Energy saving)***	O
External On/Off	O	
Installation	Drain Pump	X
	High Ceiling Operation*	X
Special Functions	Wi-Fi Control	Accessory
	Comfort Cooling (Humidity Control)***	O
	Auto Elevation Grille	X
	Human Detection Function***	X
	Floor Detection Function***	X

Note

- O : Applied, X : Not Applied, - : Unconfirmed or irrelevant
- Embedded : A kit is provided by default for using this function when the product is manufactured.
- Accessory : Ordered and purchased separately the accessory package referring to the model name provided and install at field.
- Accessory line-ups varies by region, so check your local catalogue or local sales material.
- Some functions can be limited by remote controller.
- In case of cassette type indoor units, Plasma kit and Auto Elevation Grille functions are not applicable at the same time.
- 'Auto Mode' varies depending on the outdoor unit type.
 - Auto Change Over(Single Heat Pump Outdoor Unit)
 - Auto Mode Select(Multi Heat Pump Outdoor Unit)

2. AVNW48GM2P1

- Auto Intensity Control(Cooling Only Outdoor Unit)
- * : These functions need to connect the wired remote controller.
- ** : This functions need to connect to the Standard II / III wired remote controller.
- *** : This functions need to connect to the Standard III wired remote controller.

2. AVNW48GM2P1

2.3 Accessory Compatibility List

Category	Accessory Name	Model Name	Description	Compatibility
Remote Controller	Wired - Premium	PREMTA000	-	O
		PREMTA000A	-	O
		PREMTA000B	-	O
	Wired - RS3 (Standard III)	PREMTB100	White	X
		PREMTBB10	Black	X
	Wired - RS2 (Standard II)	PREMTB001	White	X
		PREMTBB01	Black	X
	Wired - Simple	PQRCVCL0QW	White	X
		PQRCVCL0Q	Black	X
	Wired - Simple for hotel	PQRCHCA0QW	White	X
		PQRCHCA0Q	Black	X
	Wireless	PQWRCQ0FDB	For Cooling only	O
		PQWRHQ0FDB	For Heat pump	O
		PWLSSB21C	For Cooling only	O
		PWLSSB21H	For Heat pump	O
Dry Contact	Simple	PDRYCB000	1 input port, AC 220 - 240V	O
		PDRYCB100	1 input port, AC 24V	O
	Communication	PDRYCB400	2 input port	O
		PDRYCB300	8 input port, For 3rd party Thermostat	O
		PDRYCB320	8 input port, For 3rd Party Thermostat (Analog Input)	O
PDRYCB500	For 3rd Party Controller(Modbus RTU)	O		
Integration Device	Remote Temperature sensor	PQRSTA0	-	O
	Group Control wire	PZCWRCG3	Cable Assembly for group control (Y-type cable : 0.25m, cable : 9.6m)	O
ETC	Extension wire	PZCWRC1	Extension wire for IDU-wired remote controller (9.6m)	O
	2-Remo Control wire	PZCWRC2	-	X
	Wi-Fi Modem	PWFMD200	-	O
	Wi-Fi Extension cable	PWYREW000	USB Extension cable : 10 m	O
	Independent Power Module	PRIP0	For Multi V Indoor Unit	X
	Multi-tenant Power module	PINPMB001	For Multi V Indoor Unit	X
	Refrigerant Leakage Detector	PRLDNVS0	For Multi V Indoor Unit (R410A)	X
	Human Detection Sensor	PTVSMA0	For Cassette 4-way	X
		PTVSAA0	For Cassette Dual Vane 4-way	X
	Floor Detection Sensor	PTFSMA0	For Cassette Dual Vane 4-way	X
	Auto Elevation Grille	PTEGM0	For Cassette 4-way	X
	Air Purification Kit	PTAHTP0	For Cassette 1-way	X
		PTAHMP0	For Cassette 4-way	X
		PTAHYP0	For Cassette Round	X
	EEV Kit	PRGK024A0	For Multi V Indoor Unit	X
	Auxiliary Heater Relay Kit	PRARS1	For Wall Mounted / Art Cool Indoor Units	O
		PRARH1	For Cassette / Duct Indoor Units	O
	Ventilation Kit	PTVK430	For TR/TQ/TP/TN/TM Chassis	X
		PTVK410 / PTVK420	For TP/TN/TM Chassis	X
	Cassette Cover	PTDCQ	For TR/TQ Chassis	X
PTDCM		For TP/TN/TM Chassis	X	
PTDCA		For TM-A/TP-B Chassis	X	

Note

- O: Possible, X: Impossible, -: Unconfirmed or irrelevant.
- *: Some advanced functions controlled by individual controller cannot be operated.
- Air Purification Kit and Auto Elevation Grille are not applicable at the same time.
- If there is a difference in development time between the product and the remote controller, some functions cannot be operated.
- If you need more detail, please refer to the Control(BECON) PDB or the manual of product.
(<http://partner.lge.com/global> : Home> Doc.Library> Product > Control(BECON)).

2. AVNW48GM2P1

2.4 Dimensions

2.4.1 Product

[Unit: mm]
Chassis code : VM2
DWG No. : TAZ35266401_Rev01

The technical drawings include a perspective view of the unit, a front view with dimensions (1418, 709, 355, 1987, 92, 216, 355, 216), a side view with dimensions (188, 37, 60, 61, 110, 115), and three section views (A-A, B-B, C-C) showing internal components and air flow paths. Key dimensions include 236, 1600, 800, 690, 456, 214, 135, 1343, and 1833. Callouts 1, 2, 3, 4, 5, 6, and 7 identify specific components.

Note

- Unit should be installed in compliance with the installation manual in the product box.
- Unit should be grounded in accordance with the local regulations or applicable national codes.
- All electrical components and materials to be supplied from the site must comply with the local regulations or international codes.

No.	Part Name	Description
7	Liquid pipe connection	-
6	Gas pipe connection	-
5	Refrigerant pipe and cable routing hole	Knock-out type
4	Drain hose routing hole	Knock-out type
3	Remote Controller Signal Receiver	For wireless type
2	Air outlet	-
1	Air intake	-

2. AVNW48GM2P1

2.4.2 Installation Space

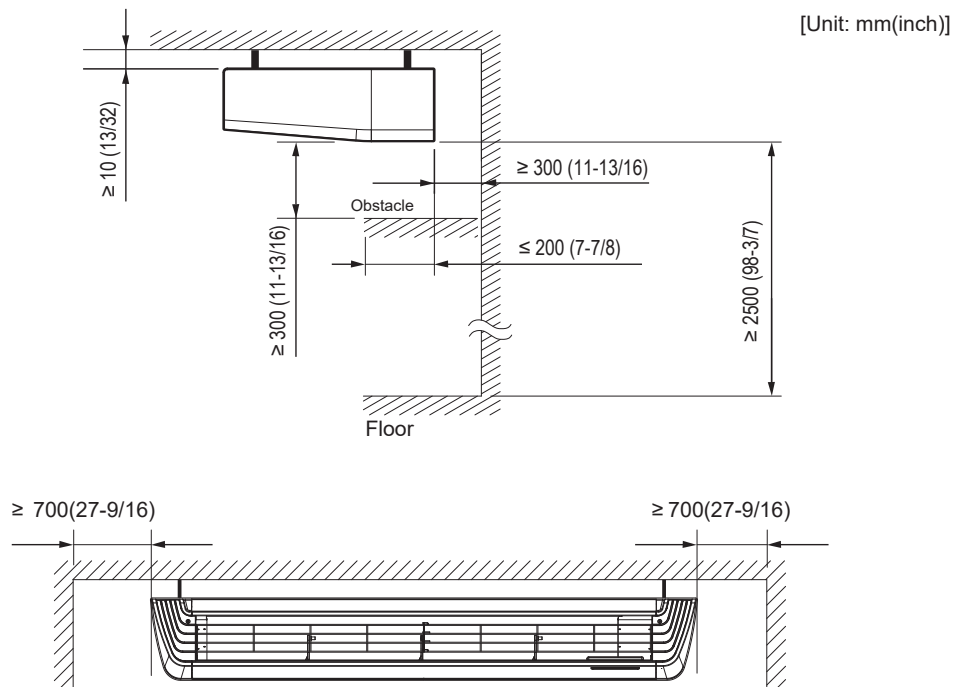
**Note**

- Places where products are installed should not be any obstacles to the air circulation or installation. Ensure the spaces from the wall, ceiling, or other obstacles.
- According to type of indoor unit, external appearance or installed structure could be different.
- According to product type, model line up, sales region..etc, applicability of each chassis could be different.

2. AVNW48GM2P1

2.5 Piping Diagrams

2.5.1 Normal

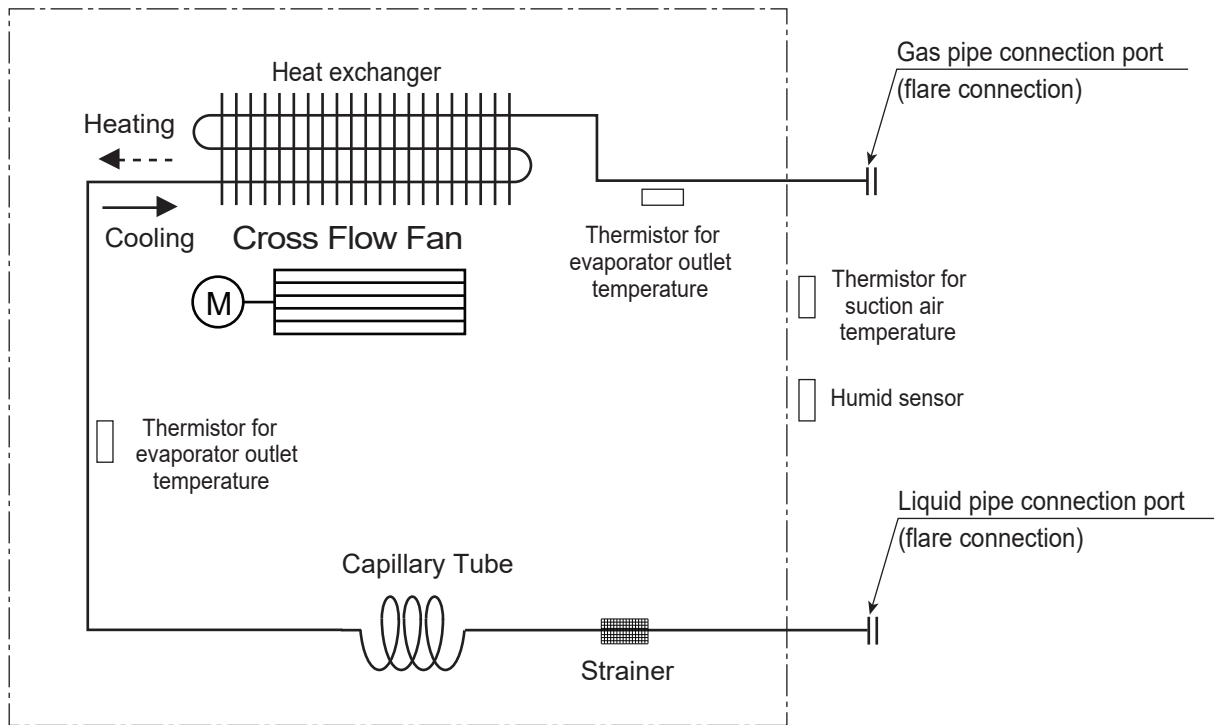

2. AVNW48GM2P1

2.6 Wiring Diagrams

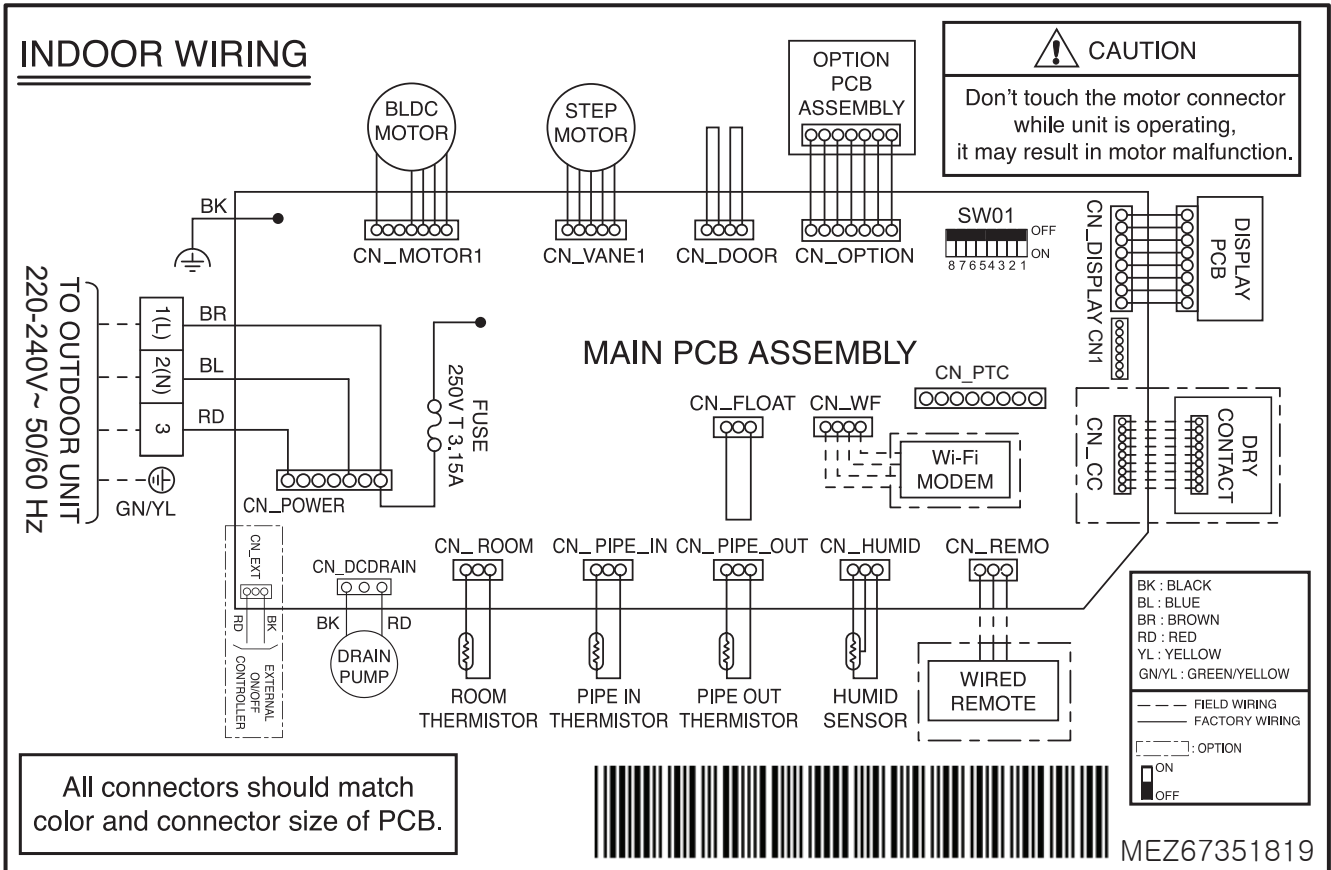

All connectors should match color and connector size of PCB.



2. AVNW48GM2P1

2.7 Sound Levels

2.7.1 Pressure Levels

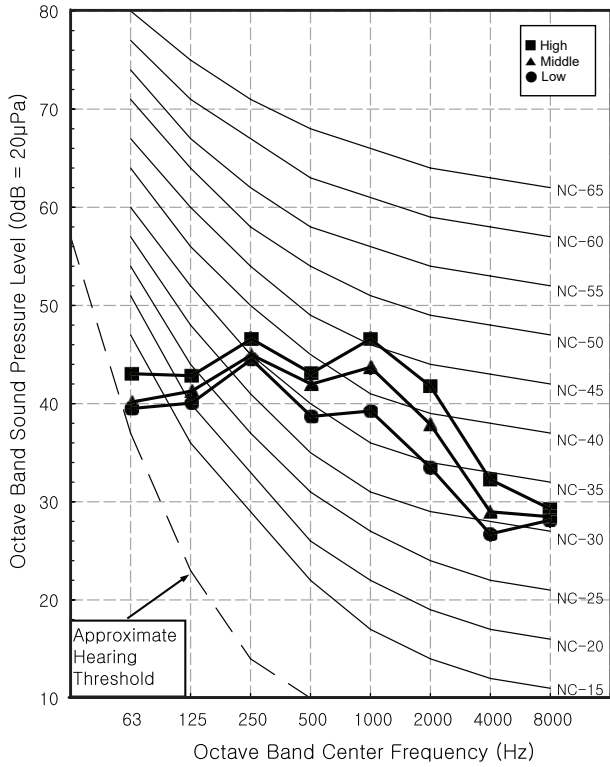

Sound level [dB(A), @ Standard condition]	
Cooling ((SH)/H/M/L)	- / 50.0 / 46.0 / 42.0
Heating ((SH)/H/M/L)	- / 50.0 / 46.0 / 42.0

Note

- Sound measured at some distance away from the center of the unit.
- Data is valid at free field condition.
- Reference accoustic pressure 0dB = 20µPa.
- Data is valid at nominal operation condition.
Refer to the Model Specifications for nominal conditions(Power source and Ambient temperature, etc)
- Sound levels can be increased in accordance with installation and operating conditions.
(Static pressure mode, used air guide, Room target temperature setting, etc)
- Sound pressure level is measured on the rated condition in the anechoic rooms by ISO 3745 standard.
Therefore, these values can be increased owing to ambient conditions during operation.

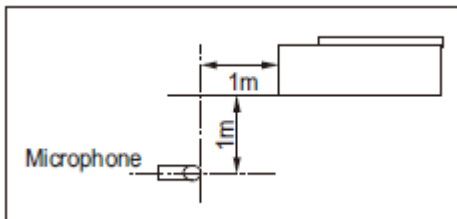

2. AVNW48GM2P1

2.8 Air flow and temperature distributions

2.8.1 Cooling operation

Cooling

Discharge angle: 0°

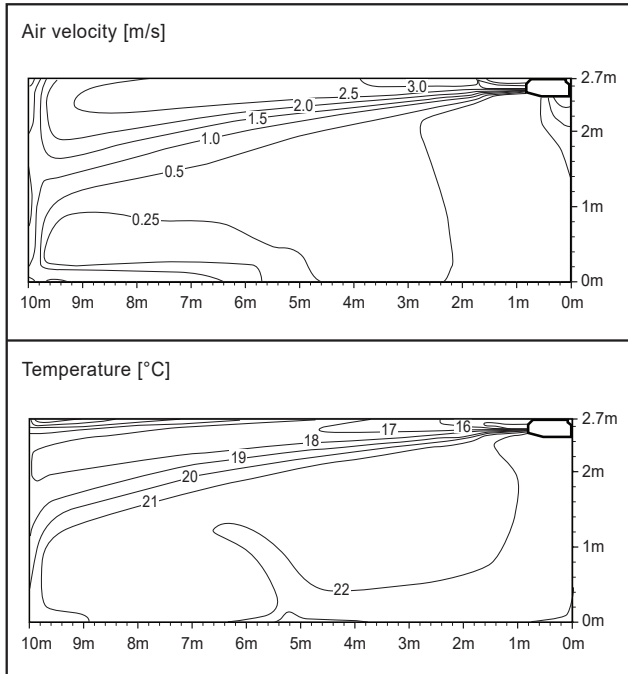

Note

- These figures are accordance with normal certain condition and environment.
(Airflow step is 'High', Air discharge angle is fixed as indicated angle.)
- Indoor airflow distribution under actual installation or operating conditions depends on ambient temperature, ceiling height, product installation direction / location, indoor / Heating load, and other obstacles, etc.

2. AVNW48GM2P1

2.8.2 Heating operation

Discharge angle: 0°

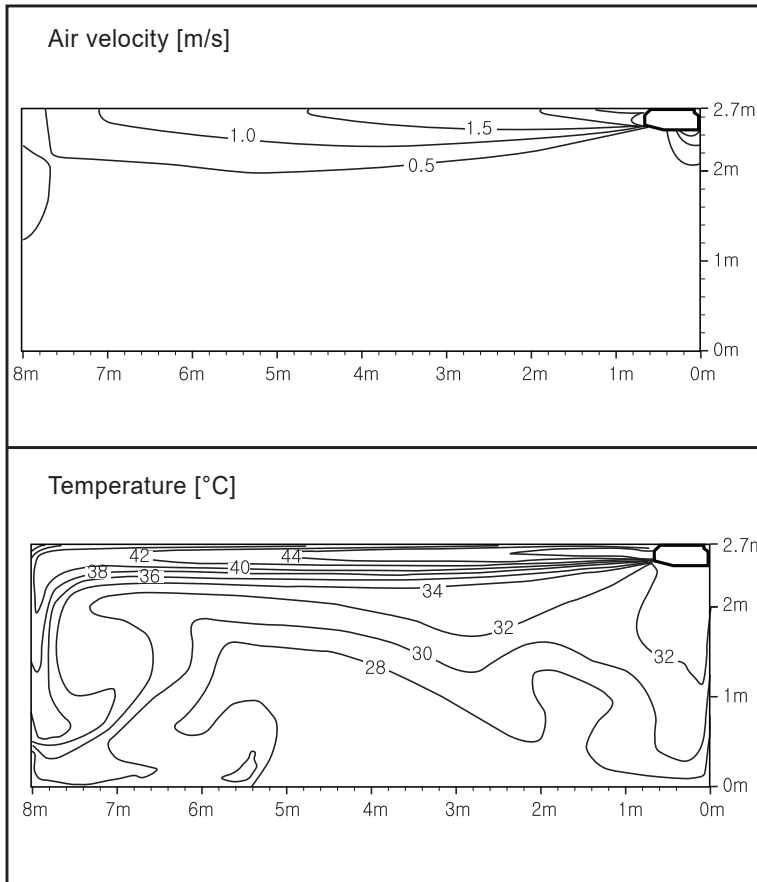

Note

- These figures are accordance with normal certain condition and environment.
(Airflow step is 'High', Air discharge angle is fixed as indicated angle.)
- Indoor airflow distribution under actual installation or operating conditions depends on ambient temperature, ceiling height, product installation direction / location, indoor / Heating load, and other obstacles, etc.

3. AVNW60GM2P1

3.1 Specifications

Category		Unit	Specification
Major	Minor		
Classification	Chassis	-	VM2
Power Supply	Case 1	-	220, 1, 60
	Case 2	-	-
	Limit Range of Voltage(Case 1)	V	198~242
	Limit Range of Voltage(Case 2)	V	-
Cooling Capacity	Nominal	kW	15.24
		Btu/h	52,000
Heating Capacity	Nominal	kW	17.00
		Btu/h	58,000
Power Input(Indoor)	H/M/L	W	-
Running Current	H/M/L	A	-
Indoor Fan	Type	-	CFF
	Quantity	EA	2
	Air Flow Rate((SH)/H/M/L)	m ³ /min	- / 30.0 / 25.0 / 20.0
	Air Flow Rate Range(Min~Max)	m ³ /min	20.0~30.0
	External Static Pressure_Factory Set	Pa	-
Indoor Fan Motor	Type	-	BLDC
	Drive	-	-
	Output	W	125
		No.	1
Dehumidification Rate	-	ℓ/h	6.50
Heat Exchanger	Rows x Columns x FPI	-	3 x 18 x 18
	No.	-	1
	Fin Type	-	Louver
	Face Area	m ²	0.46
Dimensions	Net(W x H x D)	mm	1,600 x 235 x 690
	Shipping(W x H x D)	mm	1,715 x 317 x 768
Weight	Net	kg	36.9
	Shipping	kg	45.5
Exterior	Color	-	Morning Fog
	RAL (Classic)	-	RAL 9001
Air Filter	Type	-	Long Life
Protection Device	Fuse	-	O
	Overload Protector for Fan Motor	-	Thermal Protector for Fan Motor
Refrigerant	Type	-	R410A
	Control Type	-	-
Drain Pipe(Natural Drainage)	O.D / I.D	mm(inch)	21.5 / 16.0
Drain Pipe(using Drain Pump)	O.D / I.D	mm(inch)	-
Pipe Connecting Socket	Liquid	mm(inch)	Φ9.52 (3/8)
	Gas	mm(inch)	Φ19.05 (3/4)
	Connection Type(Liquid)	-	Flare
	Connection Type(Gas)	-	Flare
Sound Pressure Level(Indoor Unit)	Cooling ((SH)/H/M/L)	dB(A)	- / 50.0 / 46.0 / 42.0
	Heating ((SH)/H/M/L)	dB(A)	- / 50.0 / 46.0 / 42.0
Measurement Standard (Pressure Level)	-	-	ISO 3745
Sound Power Level(Indoor Unit)	Cooling ((SH)/H/M/L)	dB(A)	-
	Heating ((SH)/H/M/L)	dB(A)	-
Measurement Standard (Power Level)	-	-	-
Connecting Cable	Power and Communication cable(H07RN-F)	mm ² × cores	0.75 x 4

3. AVNW60GM2P1

Category		Unit	Specification
Major	Minor		
Power Supply Type to Indoor	-	-	-
Electrical Characteristic	Indoor Fan Motor_Full Load Amperes (FLA)	A	0.6

Note

- Due to our policy of innovation some specifications may be changed without notification.
- Wiring cable size must comply with the applicable local and national code.
And "Electric characteristics" should be considered for electrical work and design.
- Especially the power cable and circuit breaker should be selected in accordance with that.
- Sound Level Values are measured at Noise Measuring chamber accordance with standard.
Therefore, these values depend on the ambient conditions and values are normally higher in actual operation.

3. AVNW60GM2P1

3.2 List of Functions

Category	Functions	Availability
Air Flow	Air Supply Outlet	1
	Airflow Direction Control (left & right)	X
	Airflow Direction Control (up & down)	Auto
	Auto Swing (left & right)	X
	Auto Swing (up & down)	O
	Airflow Steps (fan/cool/heat)	4 / 5 / 5
	Fan Speed Auto*	O
	Power Cool/Heat	O / O
	Swirl Wind*	X
	Refresh Mode**	X
	Smart Mode**	X
	Indirect Wind*	O
	Direct Wind*	O
	Dry Operation	O
Air Purification	Air Purify	X
	Ionizer	X
	UV-C	X
	Allergy Filter	X
	Pre-Filter	O
	PM1.0 Filter	X
Reliability	Hot Start	O
	Self Diagnosis	O
Convenience	Auto Mode	O
	Auto Dry Operation**	O
	Auto Restart	O
	Child Lock*	O
	Forced Operation	X
	Group Control*	O
	Sleep Timer**	O
	Turn On/Off Reservation**	O
	Schedule**	O
	Two Thermistor Control*	O
	Time Limit Control (Energy saving)***	O
External On/Off	O	
Installation	Drain Pump	X
	High Ceiling Operation*	X
Special Functions	Wi-Fi Control	Accessory
	Comfort Cooling (Humidity Control)***	O
	Auto Elevation Grille	X
	Human Detection Function***	X
	Floor Detection Function***	X

Note

- O : Applied, X : Not Applied, - : Unconfirmed or irrelevant
- Embedded : A kit is provided by default for using this function when the product is manufactured.
- Accessory : Ordered and purchased separately the accessory package referring to the model name provided and install at field.
- Accessory line-ups varies by region, so check your local catalogue or local sales material.
- Some functions can be limited by remote controller.
- In case of cassette type indoor units, Plasma kit and Auto Elevation Grille functions are not applicable at the same time.
- 'Auto Mode' varies depending on the outdoor unit type.
 - Auto Change Over(Single Heat Pump Outdoor Unit)
 - Auto Mode Select(Multi Heat Pump Outdoor Unit)

3. AVNW60GM2P1

- Auto Intensity Control(Cooling Only Outdoor Unit)
- * : These functions need to connect the wired remote controller.
- ** : This functions need to connect to the Standard II / III wired remote controller.
- *** : This functions need to connect to the Standard III wired remote controller.

3. AVNW60GM2P1

3.3 Accessory Compatibility List

Category	Accessory Name	Model Name	Description	Compatibility
Remote Controller	Wired - Premium	PREMTA000	-	O
		PREMTA000A	-	O
		PREMTA000B	-	O
	Wired - RS3 (Standard III)	PREMTB100	White	X
		PREMTBB10	Black	X
	Wired - RS2 (Standard II)	PREMTB001	White	X
		PREMTBB01	Black	X
	Wired - Simple	PQRCVCL0QW	White	X
		PQRCVCL0Q	Black	X
	Wired - Simple for hotel	PQRCHCA0QW	White	X
		PQRCHCA0Q	Black	X
	Wireless	PQWRCQ0FDB	For Cooling only	O
		PQWRHQ0FDB	For Heat pump	O
		PWLSSB21C	For Cooling only	O
		PWLSSB21H	For Heat pump	O
Dry Contact	Simple	PDRYCB000	1 input port, AC 220 - 240V	O
		PDRYCB100	1 input port, AC 24V	O
	Communication	PDRYCB400	2 input port	O
		PDRYCB300	8 input port, For 3rd party Thermostat	O
		PDRYCB320	8 input port, For 3rd Party Thermostat (Analog Input)	O
PDRYCB500	For 3rd Party Controller(Modbus RTU)	O		
Integration Device	Remote Temperature sensor	PQRSTA0	-	O
	Group Control wire	PZCWRCG3	Cable Assembly for group control (Y-type cable : 0.25m, cable : 9.6m)	O
ETC	Extension wire	PZCWRC1	Extension wire for IDU-wired remote controller (9.6m)	O
	2-Remo Control wire	PZCWRC2	-	X
	Wi-Fi Modem	PWFMD200	-	O
	Wi-Fi Extension cable	PWYREW000	USB Extension cable : 10 m	O
	Independent Power Module	PRIP0	For Multi V Indoor Unit	X
	Multi-tenant Power module	PINPMB001	For Multi V Indoor Unit	X
	Refrigerant Leakage Detector	PRLDNVS0	For Multi V Indoor Unit (R410A)	X
	Human Detection Sensor	PTVSMA0	For Cassette 4-way	X
		PTVSAA0	For Cassette Dual Vane 4-way	X
	Floor Detection Sensor	PTFSMA0	For Cassette Dual Vane 4-way	X
	Auto Elevation Grille	PTEGM0	For Cassette 4-way	X
	Air Purification Kit	PTAHTP0	For Cassette 1-way	X
		PTAHMP0	For Cassette 4-way	X
		PTAHYP0	For Cassette Round	X
	EEV Kit	PRGK024A0	For Multi V Indoor Unit	X
	Auxiliary Heater Relay Kit	PRARS1	For Wall Mounted / Art Cool Indoor Units	O
		PRARH1	For Cassette / Duct Indoor Units	O
	Ventilation Kit	PTVK430	For TR/TQ/TP/TN/TM Chassis	X
		PTVK410 / PTVK420	For TP/TN/TM Chassis	X
	Cassette Cover	PTDCQ	For TR/TQ Chassis	X
PTDCM		For TP/TN/TM Chassis	X	
PTDCA		For TM-A/TP-B Chassis	X	

Note

- O: Possible, X: Impossible, -: Unconfirmed or irrelevant.
- *: Some advanced functions controlled by individual controller cannot be operated.
- Air Purification Kit and Auto Elevation Grille are not applicable at the same time.
- If there is a difference in development time between the product and the remote controller, some functions cannot be operated.
- If you need more detail, please refer to the Control(BECON) PDB or the manual of product.
(<http://partner.lge.com/global> : Home> Doc.Library> Product > Control(BECON)).

3. AVNW60GM2P1

3.4 Dimensions

3.4.1 Product

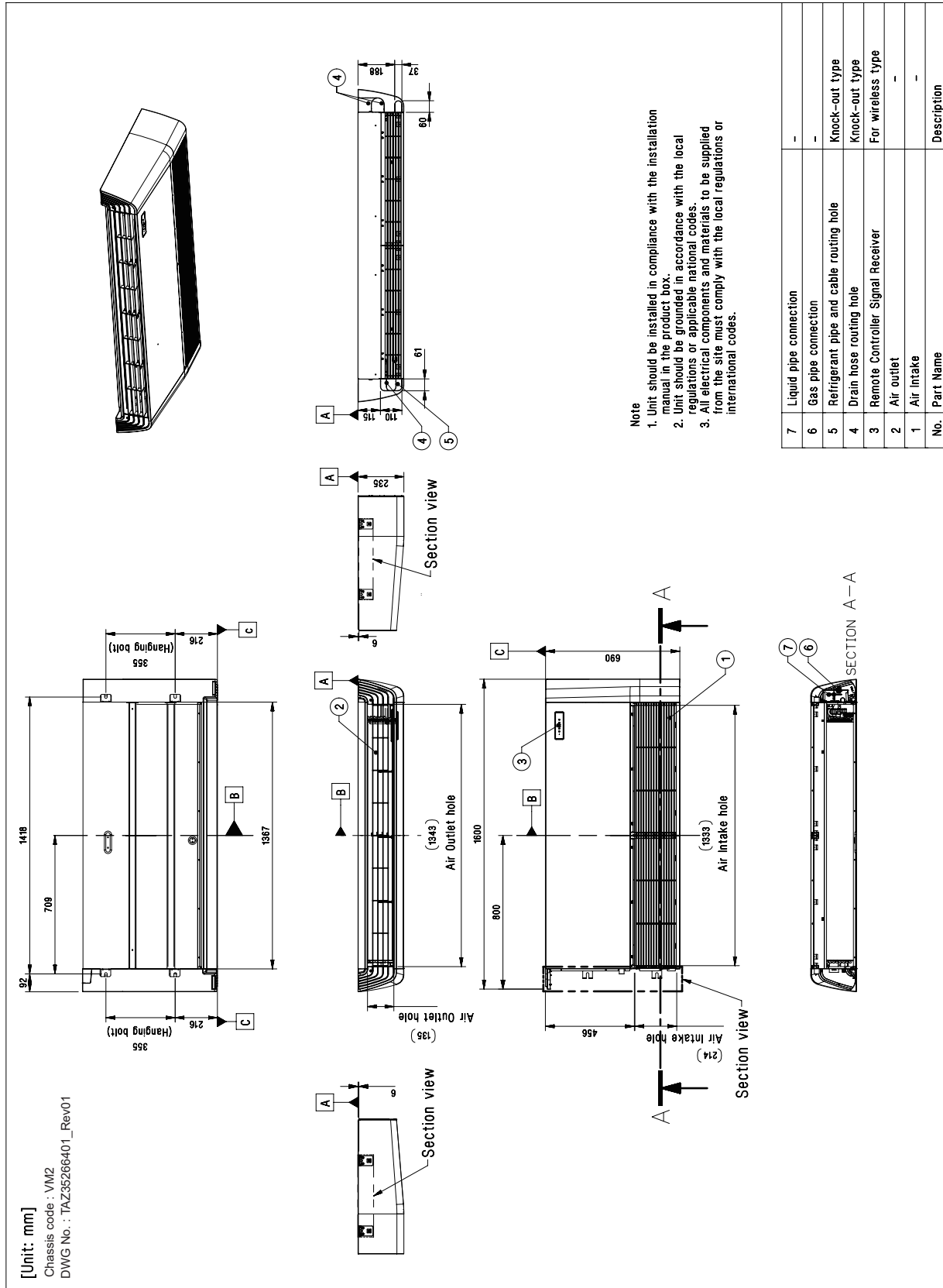

3. AVNW60GM2P1

3.4.2 Installation Space

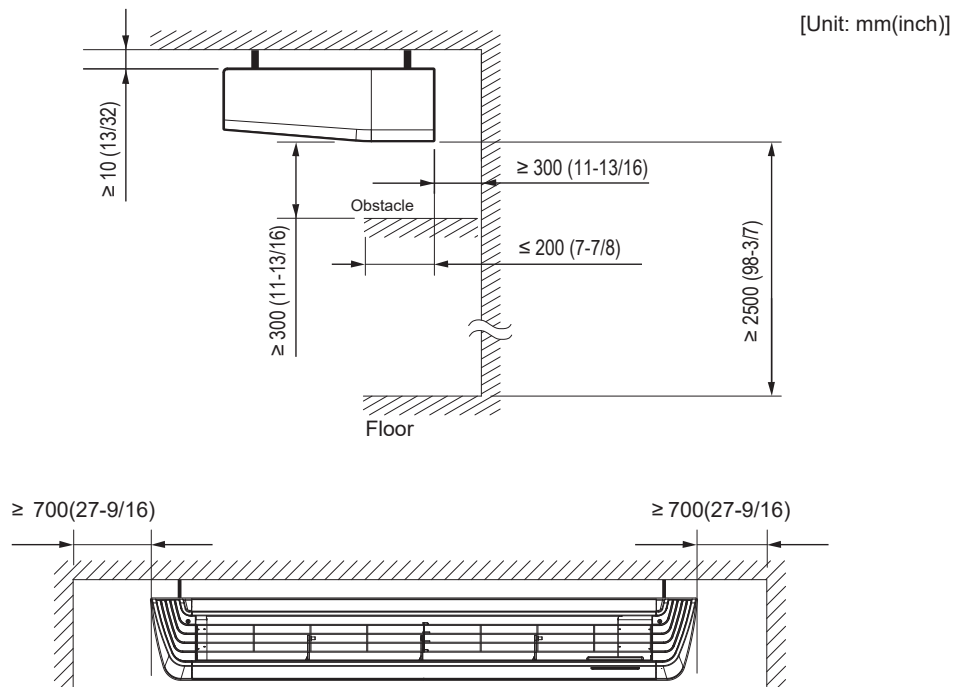

Note

- Places where products are installed should not be any obstacles to the air circulation or installation. Ensure the spaces from the wall, ceiling, or other obstacles.
- According to type of indoor unit, external appearance or installed structure could be different.
- According to product type, model line up, sales region..etc, applicability of each chassis could be different.

3. AVNW60GM2P1

3.5 Piping Diagrams

3.5.1 Normal

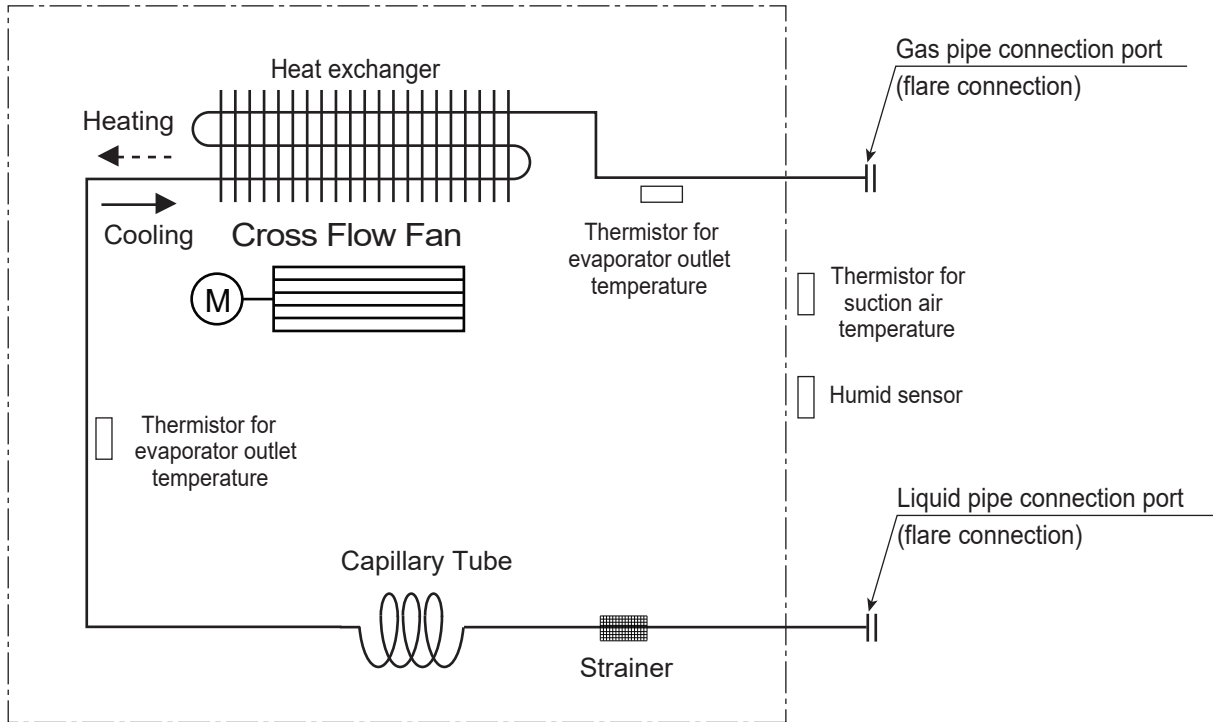

3. AVNW60GM2P1

3.6 Wiring Diagrams

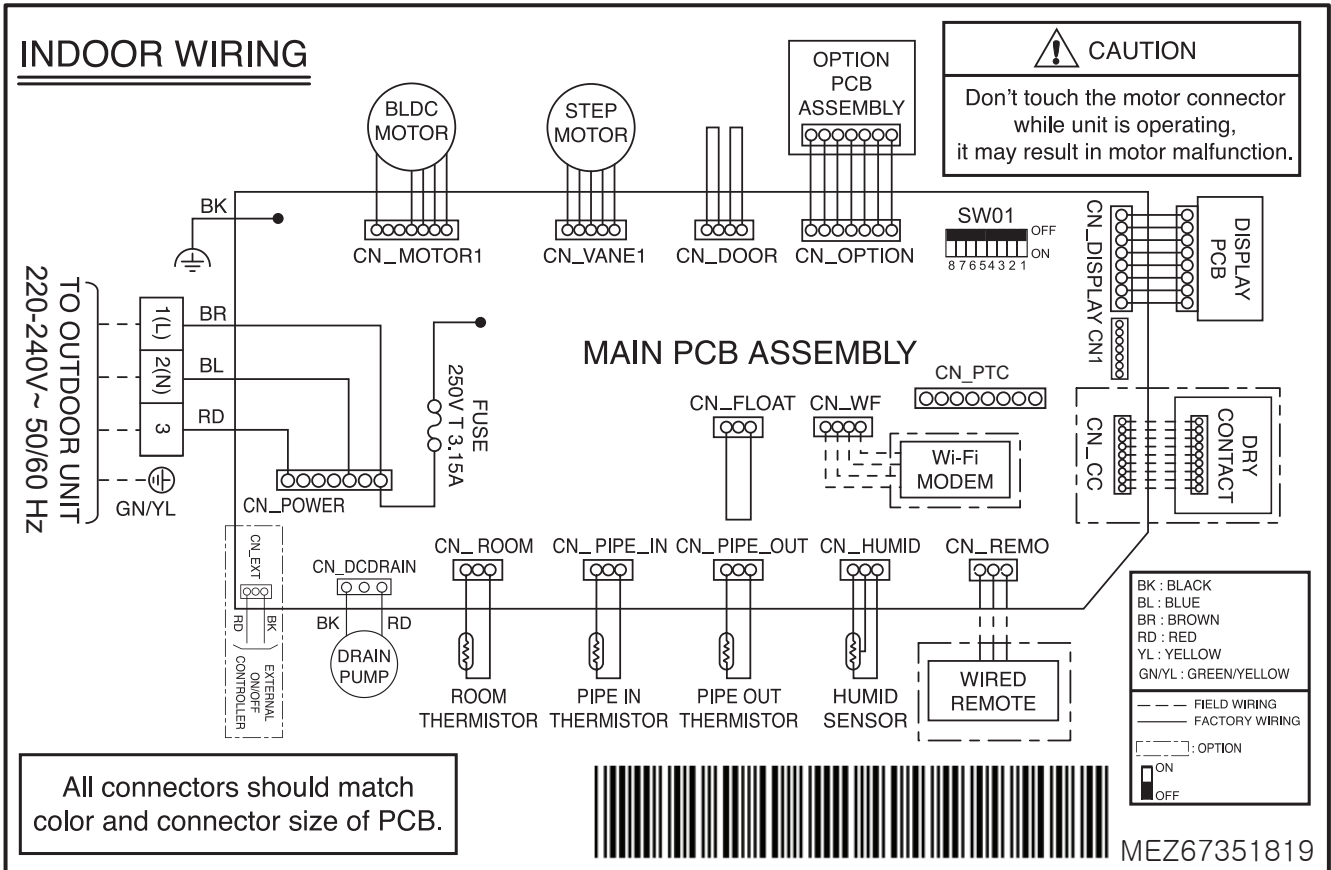

3. AVNW60GM2P1

3.7 Sound Levels

3.7.1 Pressure Levels

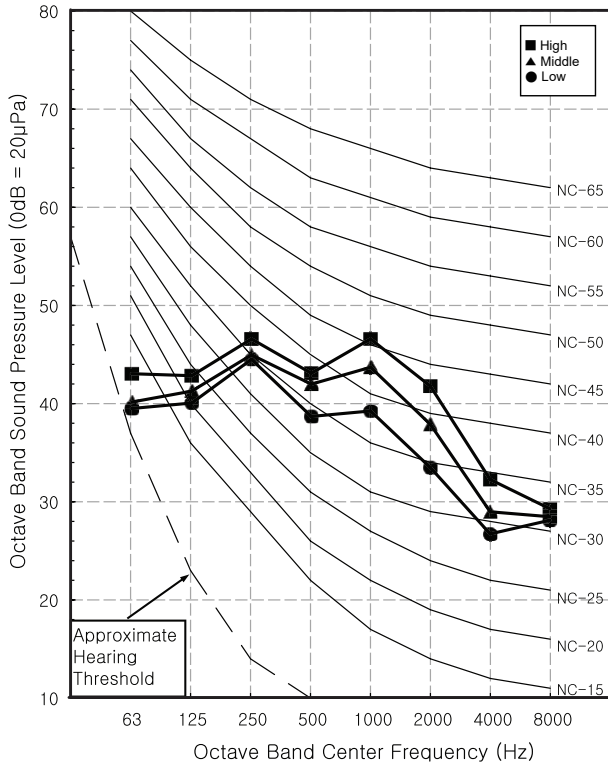

Sound level [dB(A), @ Standard condition]	
Cooling ((SH)/H/M/L)	- / 50.0 / 46.0 / 42.0
Heating ((SH)/H/M/L)	- / 50.0 / 46.0 / 42.0

Note

- Sound measured at some distance away from the center of the unit.
- Data is valid at free field condition.
- Reference accoustic pressure 0dB = 20µPa.
- Data is valid at nominal operation condition.
Refer to the Model Specifications for nominal conditions(Power source and Ambient temperature, etc)
- Sound levels can be increased in accordance with installation and operating conditions.
(Static pressure mode, used air guide, Room target temperature setting, etc)
- Sound pressure level is measured on the rated condition in the anechoic rooms by ISO 3745 standard.
Therefore, these values can be increased owing to ambient conditions during operation.

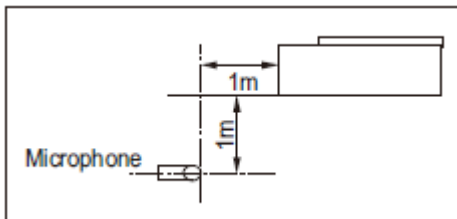

3. AVNW60GM2P1

3.8 Air flow and temperature distributions

3.8.1 Cooling operation

Cooling

Discharge angle: 0°

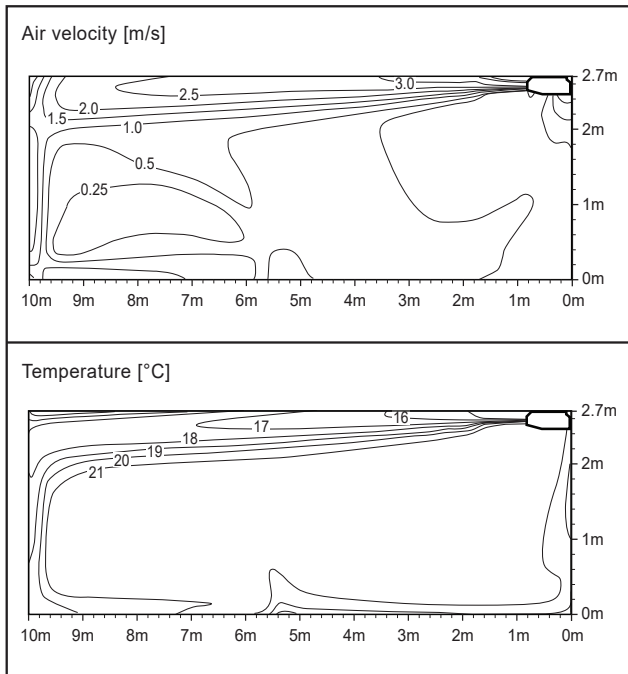

Note

- These figures are accordance with normal certain condition and environment.
(Airflow step is 'High', Air discharge angle is fixed as indicated angle.)
- Indoor airflow distribution under actual installation or operating conditions depends on ambient temperature, ceiling height, product installation direction / location, indoor / Heating load, and other obstacles, etc.

3. AVNW60GM2P1

3.8.2 Heating operation

Discharge angle: 0°

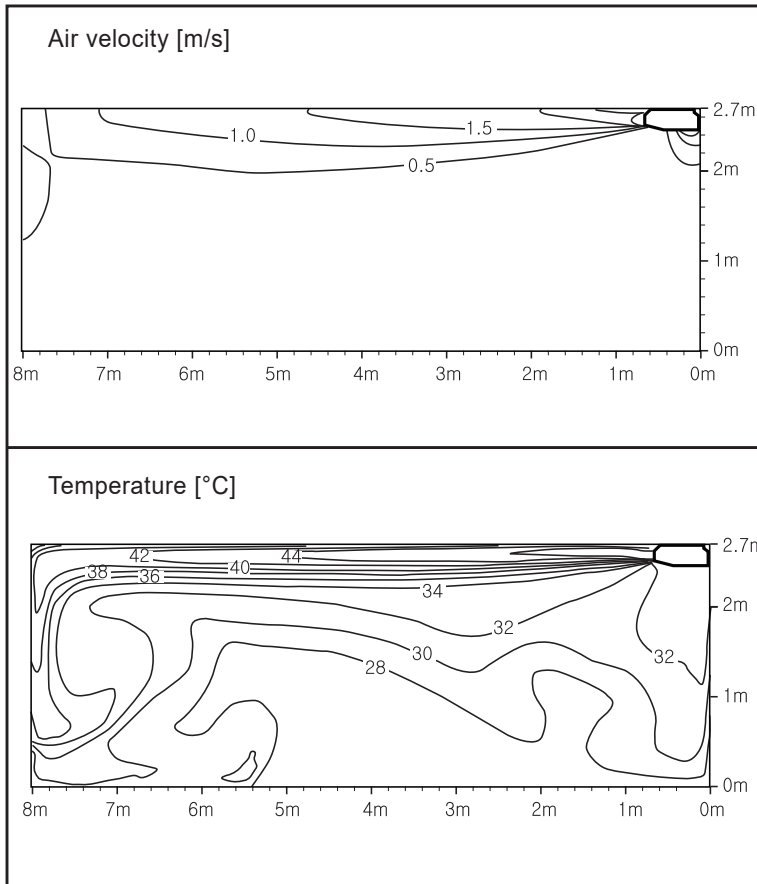

Note

- These figures are accordance with normal certain condition and environment.
(Airflow step is 'High', Air discharge angle is fixed as indicated angle.)
- Indoor airflow distribution under actual installation or operating conditions depends on ambient temperature, ceiling height, product installation direction / location, indoor / Heating load, and other obstacles, etc.

Accessory

Front Panel

Air Purification Kit

1. PT-AAGW0

1.1 Specifications

Category		Unit	Specification
Major	Minor		
Model Name	Factory model	-	PT-AAGW0
	Buyer model	-	PT-AAGW0
Panel Type	-	-	Standard
Panel Exterior	Glossy / Matt	-	-
	Color	-	White
	RAL (Classic)	-	RAL 9003
	Grille Type (Grille / Grid)	-	Grid
Panel Dimension	Net (W x H x D)	mm	950 x 35 x 950
	Shipping (W x H x D)	mm	1,006 x 102 x 1,006
Panel Weight	Net	kg	7.1
	Shipping	kg	9.3
Panel Function	PM1.0 Sensor	-	X
Panel Accessory	Air Purification Kit	-	X
	Floor Detection Sensor	-	PTFSMA0
	Human Detection Sensor	-	PTVSAA0

Note

- Some functions need to connect to the Standard III wired remote controller.
- Accessory : Ordered and purchased separately the accessory package referring to the model name provided and install at field

2. PT-AFGW0

2.1 Specifications

Category		Unit	Specification
Major	Minor		
Model Name	Factory model	-	PT-AFGW0
	Buyer model	-	PT-AFGW0
Panel Type	-	-	Premium
Panel Exterior	Glossy / Matt	-	-
	Color	-	White
	RAL (Classic)	-	RAL 9003
	Grille Type (Grille / Grid)	-	Grid
Panel Dimension	Net (W x H x D)	mm	950x35x950
	Shipping (W x H x D)	mm	1,006x117x1,006
Panel Weight	Net	kg	7.50
	Shipping	kg	9.40
Panel Function	PM1.0 Sensor	-	O
Panel Accessory	Air Purification Kit	-	PTAHMP0
	Floor Detection Sensor	-	PTFSMA0
	Human Detection Sensor	-	PTVSAA0

Note

- Some functions need to connect to the Standard III wired remote controller.
- Accessory : Ordered and purchased separately the accessory package referring to the model name provided and install at field

1. PTAHMP0

1.1 Specifications

Category		Unit	Specification
Major	Minor		
Air Purification Kit	Applied Chassis	-	TP/TN/TM/TP-B/TM-A
	Applied Panel	-	PT-MPGW0 (U-style) / PT-AFGW0 (Dual Vane)
PM 1.0 Sensor	Size(W x H x D)	mm	59 x 45 x 22
	Supply Voltage	V	5
	Measure	-	PM1.0 / PM2.5 / PM10
HVPS	Size(W x H x D)	mm	99 X 50 X 30
	Input	-	DC 12V
	Output(Electrification / Dust Collection)	-	-7.7kV / -5.2kV
PM 1.0 Filter	Size(W x H x D)	mm	500 x 38 x 395
	Weight	g	2,090
Deodorization Filter	Material	-	Pulp + Carbon (Corrugate)
	Size(W x H x D)	mm	478 x 14 x 138
	Weight	g	180
Ionizer	Size(W x H x D)	mm	71 x 19 x 30
	Input	-	DC 12V
	Output	-	-3.2kV
	Amount of Ion Emission	EA / cc	3,000,000

2. PTAHTP0

2.1 Specifications

Category		Unit	Specification
Major	Minor		
Air Purification Kit	Applied Chassis	-	TU / TT
	Applied Panel	-	PT-UPHG0 / PT-TPHG0
PM 1.0 Sensor	Size(W x H x D)	mm	59 x 45 x 22
	Supply Voltage	V	5
	Measure	-	PM1.0 / PM2.5 / PM10
HVPS	Size(W x H x D)	mm	99 X 50 X 30
	Input	-	DC 12V
	Output(Electrification / Dust Collection)	-	-7.7kV / -5.2kV
PM 1.0 Filter	Size(W x H x D)	mm	524 x 18 x 141
	Weight	g	430
Deodorization Filter	Material	-	Pulp + Carbon (Corrugate)
	Size(W x H x D)	mm	301 x 11 x 100
	Weight	g	40
Ionizer	Size(W x H x D)	mm	71 x 19 x 30
	Input	-	DC 12V
	Output	-	-3.2kV
	Amount of Ion Emission	EA / cc	3,000,000

3. PTAHYP0

3.1 Specifications

Category		Unit	Specification
Major	Minor		
Air Purification Kit	Applied Chassis	-	TY
	Applied Panel	-	-
PM 1.0 Sensor	Size(W x H x D)	mm	59 x 45 x 16.6
	Supply Voltage	V	5
	Measure	-	PM1.0 / PM2.5 / PM10
HVPS	Size(W x H x D)	mm	99 x 50 x 30
	Input	-	DC 12V
	Output(Electrification / Dust Collection)	-	-7.7kV / -5.7kV
PM 1.0 Filter	Size(W x H x D)	mm	500 x 38 x 395
	Weight	g	2,090
Deodorization Filter	Material	-	Pulp + Carbon(corrugate)
	Size(W x H x D)	mm	478 x 14 x 138
	Weight	g	180
Ionizer	Size(W x H x D)	mm	-
	Input	-	-
	Output	-	-
	Amount of Ion Emission	EA / cc	-

Installation

Installation of Indoor Unit

1. Information for Refrigerant

1.1 R410A as an Alternative Refrigerant

The type of refrigerant applied depends on the outdoor unit cycle configuration. Ensure the refrigerant type in the specification of the indoor unit and outdoor unit to be installed.

■ Alternative Refrigerant _ R410A

- The refrigerant R410A has the property of higher operating pressure in comparison with R22. Therefore, all materials have the characteristics of higher resisting pressure than ones of R22 and this characteristic should also be considered during the installation.
- The wall thickness of the piping should comply with the relevant local and national regulations for the designed pressure. (R410A 3.8MPa)
- For high-pressure refrigerant, any unapproved pipe must not be used.
- Do not heat pipes more than necessary to prevent them from softening.
- Do not place the refrigerant container under the direct rays of the sun to prevent it from exploding.
- R410A is an azeotrope of R32 and R125 mixed at 50:50, so the ozone depletion potential(ODP) of R410A is 0.
- Since R410A is a mixed refrigerant, the required additional refrigerant must be charged in its liquid state.
If the refrigerant is charged in its gaseous state, its composition changes and the system will not work properly.
- Be careful not to install wrongly to minimize economic loss because it is expensive in comparison with R22.

1. Information for Refrigerant

1.2 Cautions for Refrigerant Leaks of R410A

< Needs to Calculation of Refrigeran concentration >

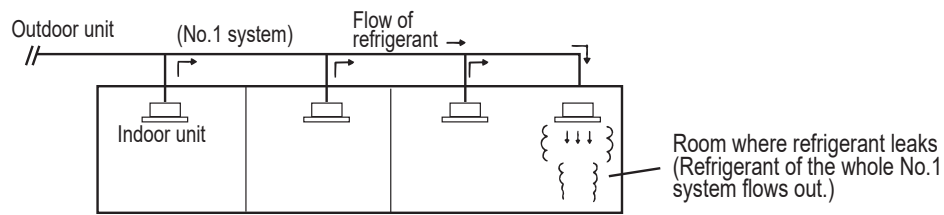

< Calculation of Room Space >

□ : Range ov Room space

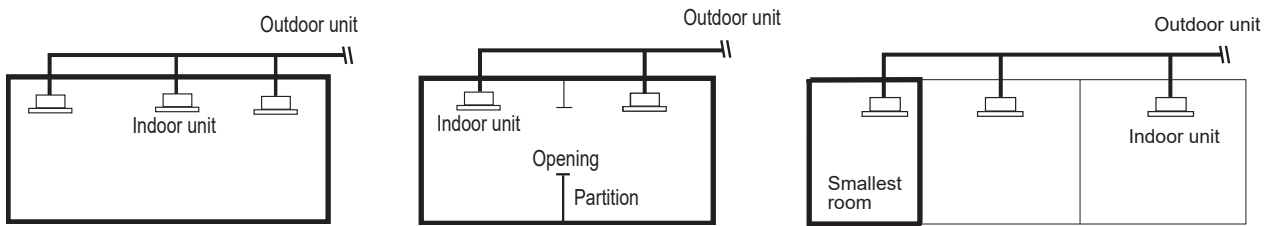

In the case of opening without door, or openings both above and below door which is more than 0.15 % to floor space)

< Countermeasure when concentration is exceed >

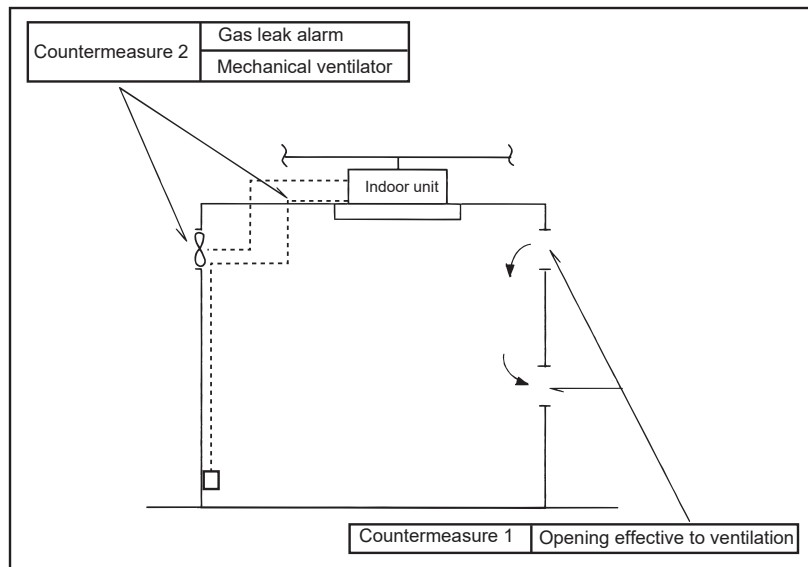

The installer and system specialist shall secure safety against leakage according to local regulations or standards. The following standards may be applicable if local regulations are not available.

■ Concentration limit : 0.44 kg/m³ (for R410A)

Concentration limit (Freon gas weight per unit air volume, kg/m³) is the limit of Freon gas concentration where immediate measures can be taken without hurting human body when refrigerant leaks in the air.

■ Calculate refrigerant concentration

Check concentration limit along following steps and take appropriate measure depending on the situation.

(1) Calculate total amount of refrigerant per each system (A, kg)

Total amount of refrigerant in the system (A, kg)

= Amount of pre-charged refrigerant per single system(B, kg) + Amount of additional replenished refrigerant(C, kg)

(B : Amount of replenished refrigerant at factory shipment)

(C : Amount of additionally replenished refrigerant depending on piping length or piping diameter by customer)

1. Information for Refrigerant

※ In case one refrigerant facility is divided into 2 or more refrigerant systems and each system is independent, amount of replenished refrigerant of each system shall be adopted.

(2) Calculate the volume of the room where indoor unit is installed as single room or the smallest room. (D, m³)

In case of room with partition and without opening which serve as passage of air to adjoining room, calculate the room space only.

- In case of room with partition but opened which serve passage of air to adjoining room, calculate the room space include space of adjoining room. (In the case of opening without door, or openings both above and below door which is more than space 0.15 % to floor space)

(3) Calculate refrigerant concentration.

Refrigerant concentration

= Total amount of refrigerant system (A, kg) ÷ Volume of smallest room where indoor unit is installed (D, m³)

[Refrigerant concentration ≤ Maximum concentration (kg/m³, R410A is 0.44)]

In case the result of calculation exceeds the concentration limit, perform the same calculations by shifting to the second smallest, and the third smallest rooms until at last the result is below the concentration limit.

■ In case the concentration exceeds the limit

When the concentration exceeds the limit, change original plan or take one of the counter measure shown below:

- Counter measure 1

Provide opening 0.15% or more size of opening to floor space both above and below door for ventilation, or provide opening without door.

- Counter measure 2

Provide gas leak alarm linked with mechanical ventilator.

- Counter measure 3

Reducing the system's refrigerant quantity by deviding into smaller separate system.

< ! > CAUTIONS

Pay a special attention to the place, such as a basement, etc. where refrigerant can stay, since refrigerant is heavier than air.

1. Information for Refrigerant

1.3 R32 as an Alternative Refrigerant

The type of refrigerant applied depends on the outdoor unit cycle configuration. Ensure the refrigerant type in the specification of the indoor unit and outdoor unit to be installed.

■ Alternative Refrigerant _ R32

- The refrigerant R32 has a lower GWP (Global Warming Potential) value, and higher efficiency than R410A. The Ozone Depletion Potential (ODP) of R32 is 0, and Global Warming Potential(GWP) is 675.
- Refrigerant piping consists of copper/steel pipes, joints, and other fittings. All components must be selected and installed in conformity with the standards pertaining to the Refrigeration Safety Regulation.
- Same piping as for R410A can be used.

< ! > WARNING

- This product contains fluorinated greenhouse gases (Refrigerant type : R32).
DO NOT LEAK refrigerant gases into the atmosphere.
- The refrigerant R32 is a Slightly Flammable gas. It does not leak normally. If the refrigerant leaks in the installed place and is in contact with a flaming source, it may cause fire, or a harmful gas.
- If there is some leak, turn off any combustion devices, ventilate the installation location, and contact the dealer from which you purchased the unit. Do not use the unit until the refrigerant leaked is repaired.
- Only use R32 as refrigerant. Other substances may cause explosions and accidents.

< ! > CAUTIONS

- The wall thickness of the piping should comply with the relevant local and national regulations for the designed pressure.
- For high-pressure refrigerant, any unapproved pipe must not be used.
- Do not heat pipes more than necessary to prevent them from softening.

1. Information for Refrigerant

1.4 Minimum Floor Area for Installation fo R32 model : accordance with IEC05

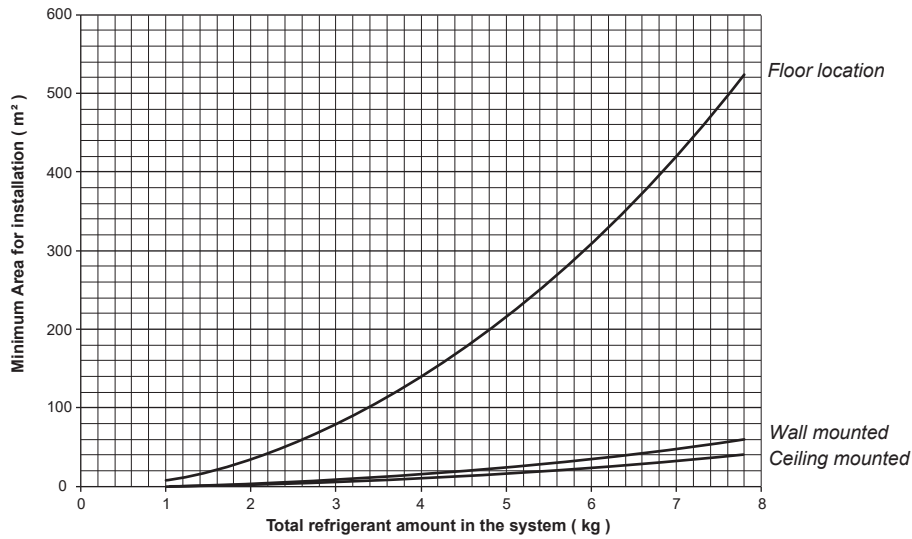

<I> CAUTIONS

- "Minimum Area for installation" might be different by revision of IEC regulation. "Minimum Area for installation" should be selected in accordance with that revision based on the local and national environment.
- The following information is according to '*IEC 60335-2-40:2013+A1:2016 Edition 5.1*'.
- Pipe-work shall be protected from physical damage and shall not be installed in an unventilated space, if that space is smaller than minimum area for installation.
- The unit should be installed, operated and stored in a room with a floor area larger than the minimum area. Use the upper graph or the below table to determine the minimum area.
 - m_c : Total refrigerant amount in the system = factory refrigerant charge + additional refrigerant amount (kg)
 - A_{min} : Minimum Area for installation of unit

m _c (kg)	A _{min}		
	Floor Location	Wall Mounted	Ceiling Mounted
1.0	8.58	0.95	0.64
1.224	12.90	1.43	0.958
1.4	16.82	1.87	1.25
1.6	21.97	2.44	1.63
1.8	27.80	3.09	2.07
2.0	34.32	3.81	2.55
2.2	41.53	4.61	3.09
2.4	49.42	5.49	3.68
2.6	58.00	6.44	4.31
2.8	67.27	7.47	5.00
3.0	77.22	8.58	5.74
3.2	87.86	9.76	6.54
3.4	99.19	11.02	7.38
3.6	111.20	12.36	8.27
3.8	123.90	13.77	9.22
4.0	137.29	15.25	10.21
4.2	151.36	16.82	11.26
4.4	166.12	18.46	12.36
4.6	181.56	20.17	13.50
4.8	197.70	21.97	14.70
5.0	214.51	23.83	15.96
5.2	232.02	25.78	17.26
5.4	250.21	27.80	18.61
5.6	269.09	29.90	20.01
5.8	288.65	32.07	21.47
6.0	308.90	34.32	22.98
6.2	329.84	36.65	24.53
6.4	351.46	39.05	26.14
6.6	373.77	41.53	27.80
6.8	396.76	44.08	29.51
7.0	420.45	46.72	31.27
7.2	444.81	49.42	33.09
7.4	469.87	52.21	34.95
7.6	495.61	55.07	36.86
7.8	522.04	58.00	38.83

1. Information for Refrigerant

1.5 Minimum Floor Area for Installation fo R32 model : accordance with IEC06

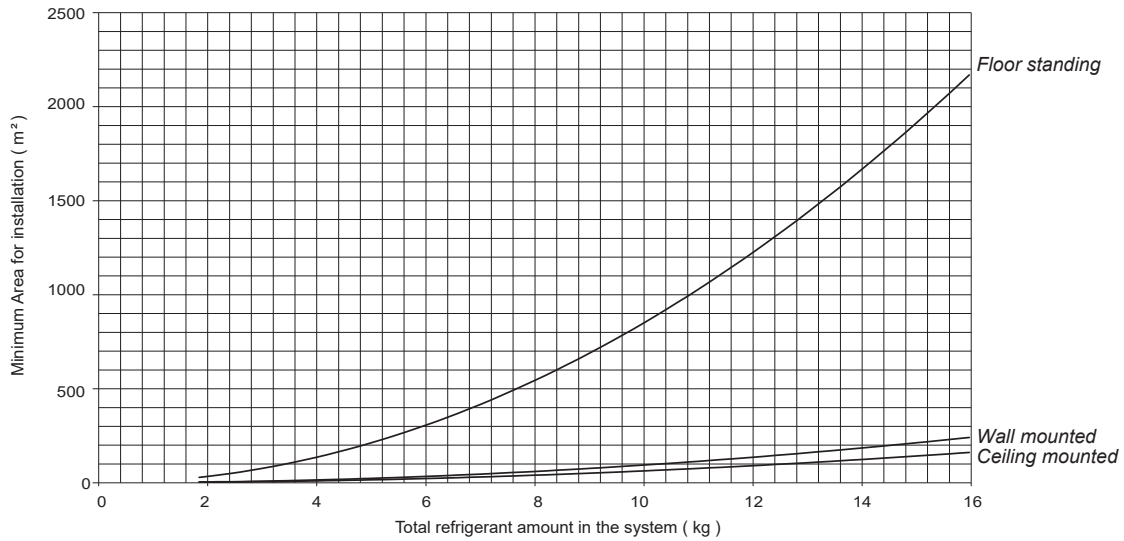

<I> CAUTIONS

• "Minimum Area for installation" might be different by revision of IEC regulation. "Minimum Area for installation" should be selected in accordance with that revision based on the local and national environment.

- The following information is according to 'IEC 60335-2-40:2018 Edition 6.0'.
- Pipe-work shall be protected from physical damage and shall not be installed in an unventilated space, if that space is smaller than minimum area for installation.
- The unit should be installed, operated and stored in a room with a floor area larger than the minimum area.

Use the below calculation formula to determine the minimum area.

- m_c : Total refrigerant amount in the system = factory refrigerant charge + additional refrigerant amount (kg)
- A_{min} : Minimum Area for installation of unit
- LFL : Lower flammability limit (kg/m³). In case of R32, LFL is 0.307 kg/m³
- h_0 : Height of unit installation

Choose the higher of the two values.

$$A_{min} = [m_c / (2.5 \times LFL^{5/4} \times h_0)]^2 \text{ or } A_{min} = m_c / (0.75 \times LFL \times h_0)$$

* The table below is a reference value, and the exact value is calculated and applied.

m_c (kg)	A_{min}	m_c (kg)	A_{min}	m_c (kg)	A_{min}
< 1.842	No Limit	6.6	27.6	11.6	85.2
1.842	3.6	6.8	29.3	11.8	88.1
2.0	3.9	7.0	31.0	12.0	91.2
2.2	4.3	7.2	32.8	12.2	94.2
2.4	4.7	7.41	34.7	12.4	97.3
2.6	5.1	7.6	36.6	12.6	100.5
2.8	5.5	7.8	38.5	12.8	103.7
3.0	5.9	8.0	40.5	13.0	107.0
3.2	6.5	8.2	42.6	13.2	110.3
3.4	7.3	8.4	44.7	13.4	113.7
3.6	8.2	8.6	46.8	13.6	117.1
3.8	9.1	8.8	49.0	13.8	120.6
4.0	10.1	9.0	51.3	14.0	124.1
4.2	11.2	9.2	53.6	14.2	127.6
4.4	12.3	9.4	55.9	14.4	131.3
4.6	13.4	9.6	58.3	14.6	134.9
4.8	14.6	9.8	60.8	14.8	138.7
5.0	15.8	10.0	63.3	15.0	142.4
5.2	17.1	10.2	65.9	15.2	146.3
5.4	18.5	10.4	68.5	15.4	150.1
5.6	19.9	10.6	71.1	15.6	154.1
5.8	21.3	10.8	73.8	15.8	158.0
6.0	22.8	11.0	76.6	15.964	161.3
6.2	24.3	11.2	79.4		
6.4	25.9	11.4	82.3		

2. Selection of the best Location

When selecting a location the product is installed, it is recommended to consider the following:

- The unit must be installed indoor area.
- Do not install the unit near the door.
- There should not be any obstacles to the air circulation or installation. Ensure the spaces from the wall, ceiling, or other obstacles.
- The place where the unit is leveled.
- The place shall allow easy water drainage.
- The place where bear a load exceeding four times of weight of the unit.
- The mounting ceiling or wall should be solid enough to protect it from the vibration.
- The place where the unit is not affected by an electrical noise.
- The place where noise prevention is taken into consideration.
- The place where the maintenance space for product is sufficient.
- The servicing inspection hole of the ceiling should be larger than the indoor unit, and that location should be approved by the customer.
- There should not be any heat source or steam near the unit. Avoid the following installation location.
 - 1) Such places as restaurants and kitchen where considerable amount of oil steam and flour is generated. These may cause heat exchange efficiency reduction, or water drops, drain pump mal-function. In these cases, take the following actions;
 - Make sure that ventilation fan is enough to cover all noxious gases from this place.
 - Ensure enough distance from the cooking room to install the unit in such a place where it may not suck oily steam.
 - 2) Avoid installing the unit in such places where cooking oil or iron powder is generated.
 - 3) Avoid places where inflammable gas is generated.
 - 4) Avoid places where noxious gas is generated.
 - 5) Avoid places near high frequency generators.

< ! > CAUTIONS

- If the temperature rise above 30°C or the humidity rise above RH 80%, additional insulation working is needed to the unit body for protection of dew formation.
 - Use the glass wool material or polyethylene foam and it make sure to be thick of 10mm at least.

3. Precautions regarding cassette indoor unit installation

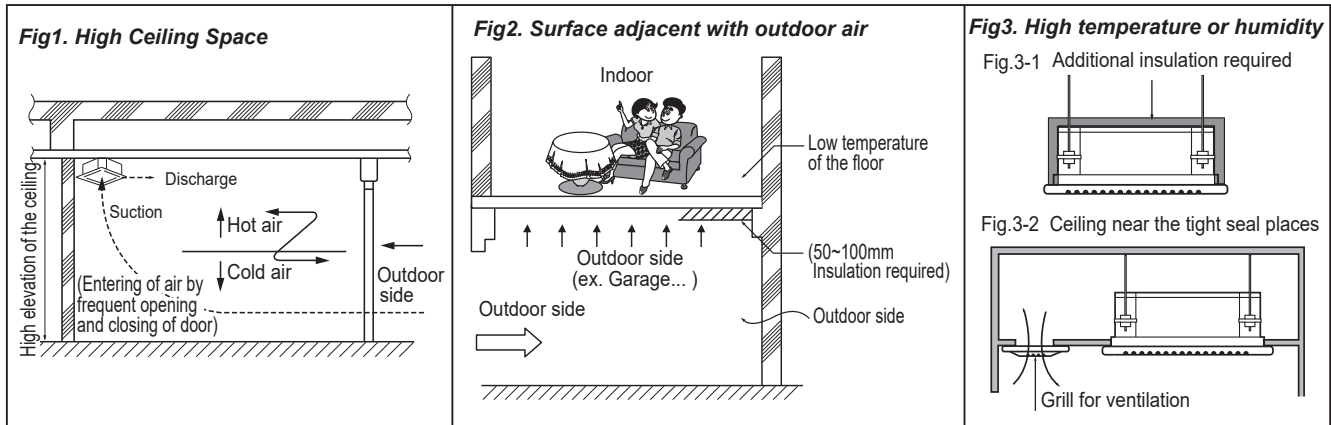

■ In case of High Ceiling space installation [Fig.1]

In general commercial places and offices though the height of the ceiling is 2.7m, and the ceiling height could be over 3 m. In such cases because of the temperature difference with the floor the heating effect can fall down.

• Countermeasure method

- Air conditioner should be able to operate in high ceiling operation mode.
- Plan to install the circulator.
- The air discharge port should be made to give more airflow to the down floor directions.
- The gate or exit of the building is protected by dual door system to minimize inflow of outdoor air.

■ In case the floor or surfaces in contact with the outdoor air directly [Fig.2]

If the floor of air conditioned room contact with the outside air, like the store room or garage, the floor temperature will be decreased and users can have a cold feeling in the feet.

In such places where the feet come in direct contact with floors will give a cold feeling to the foot.

• Countermeasure method

- Use the carpet on the floor.
(compared to the tiles the carpet over it will have a 3 degree rise in temperature)
- Insulating the floor.
- Floor heating.

<!/ CAUTIONS

In case there is a cold air intake, the duct surface may have some dew drops.

So a insulation on the duct is a must. (Insulation material: a glass wool of thickness 25 mm will be appropriate.)

■ In case of installation where high temperature or humidity [Fig.3]

- In case of places having the temperature and humidity of the surrounding water sources (sea, river etc.)
- In case the steam is generated between the false ceiling and the ceiling slab due to some nearby steam source.
- In case of temperature of 30 degree and humidity above 80%, the units body as well as the piping insulation should be strengthened. Refer to the psychrometric chart.

• Countermeasure method

- Indoor unit: Insulate the unit body with some insulation like glass wool at least 10 mm in thickness.
- Refrigerant piping: Increase the piping insulation thickness with thickness above 20 mm.
- Others: Inside the ceiling near the air tight seal places. (To escape of the humidity inside false ceiling)

4. Connecting pipes

■ Refrigerant piping work

To detail information for connecting the refrigerant pipes, please refer to the installation manual included with product.

< ! > CAUTIONS

- When mechanical connectors are reused, indoors' sealing parts shall be renewed.
- When flared joints are reused, indoors' the flare part shall be re-fabricated.

■ Piping insulation work

- Perform heat insulation work completely on both gas and the liquid pipe.
Because improper insulation will result condensate formation over pipe.
- Use the heat insulation material for the refrigerant piping which has an excellent heat resistance (over 120°C (248°F)).
- Precautions in high humidity circumstance
 - This air conditioner has been tested according to the "KS Conditions" and confirmed.
 - If it is operated for a long time in high humid atmosphere (dew point temperature: more than 23°C(73°F)), water drops are liable to fall. In this case, add heat insulation material according to the following procedure.
 - : Heat insulation material : Adiabatic glass wool with thickness of 10~20mm(13/32 ~13/16 inch).
 - : Stick glass wool on all air conditioners that are located in ceiling atmosphere.

< ! > CAUTIONS

- Make sure to insulate any field piping all the way to the piping connection inside the unit.
Any exposed piping may cause condensation or burns if touched.

5. Electrical Wiring

5.1 General Instruction

For wiring work, it is recommended to consider the following:

- All field supplied parts and materials, electric works must conform to local codes. Use copper wire only.
- Follow the "**WIRING DIAGRAM**" attached to the unit body to wire the outdoor unit, indoor units and the remote controller.
- All wiring must be performed by an authorized electrician.
- A circuit breaker capable of shutting down the power supply to the entire system must be installed.

< ! > CAUTIONS

After the confirmation of the above conditions, prepare the wiring as follows:

- Never fail to have separate power specially for this unit.
- Provide a circuit breaker switch between power source and the unit.
- Confirm the Specification of power source. Confirm that electrical capacity is sufficient.
- Be sure that the starting voltage is maintained at more than 90 percent of the rated voltage marked on the name plate.
- Confirm that the cable thickness is as specified in the power sources specification.
(Particularly note the relation between cable length and thickness.)
- Do not install the leakage breaker in a place which is wet or moist. Water or moist may cause short circuit.
- The following troubles would be caused by voltage drop-down.
 - Vibration of a magnetic switch, damage on the contact point there of, fuse breaking, disturbance to the normal function of a overload protection device.
 - Proper starting power is not given to the compressor.
 - All of the indoor units and outdoor units should be grounded. If grounding is not properly done, there is a risk of electric shock. Grounding must be done by a qualified technician.

■ Wiring Connections

- Connect the wires to the terminals on the control board individually according to the outdoor unit connection.
- Ensure that the color of the wires of outdoor unit and the terminal No. are the same as those of indoor unit respectively.
- In case of the system with multiple indoor units, mark each indoor unit as unit A, unit B, etc and be sure the terminal board wiring to the outdoor unit and indoor units are properly matched.
If wiring and piping between the outdoor unit and indoor unit are mismatched, the system may cause a malfunction.

< ! > CAUTIONS

- Make sure that the screws of the terminal are fixed tightly.
- The screw which fasten the wiring in the casing of electrical fittings are liable to come loose from vibrations to which the unit is subjected during the course of transportation. Check them and make sure that they are all tightly fastened.
(If they are loose, it could give rise to burn-out of the wires.)
- Make sure to attach the sealing material or (field supplied) to hole of wiring to prevent the infiltration of foreign particle from outside. Otherwise a short-circuit may occur inside the electric parts box.
- When clamping the wires, be sure no pressure is applied to the wire connections by using the included clamping material to make appropriate clamps. Also, when wiring, make sure the cover on the electric parts box fits snugly by arranging the wires neatly and attaching the electric parts box cover firmly. When attaching the electric parts box cover, make sure no wires get caught in the edges. Pass wiring through the wiring through holes to prevent damage to them.
- Make sure the remote controller wiring, the wiring between the units, and other electrical wiring do not pass through the same locations outside of the unit, separating them properly, otherwise electrical noise (external static) could cause product malfunction.

5. Electrical Wiring

5.2 Installation of Wired remote controller(Optional)

- Since the room temperature sensor is in the remote controller, the remote controller box should be installed in a place away from direct sunlight, high humidity and direct supply of cold air to maintain proper space temperature.
- Install the remote controller about 1.5m (5ft) above the floor in an area with good air circulation at an average temperature.
- Do not install the remote controller where it can be affected by :
 - Drafts, or dead spots behind doors and in corners.
 - Hot or cold air from ducts.
 - Radiant heat from sun or appliances.
 - Concealed pipes and chimneys.
 - Uncontrolled areas such as an outside wall behind the remote controller.
- This remote controller is equipped with a seven segment LED display. For proper display of the remote controller LED's, the remote controller should be installed properly.
(The standard height is 1.2~1.5 m (4~5ft) from floor level.)

6. Drain pipe connection

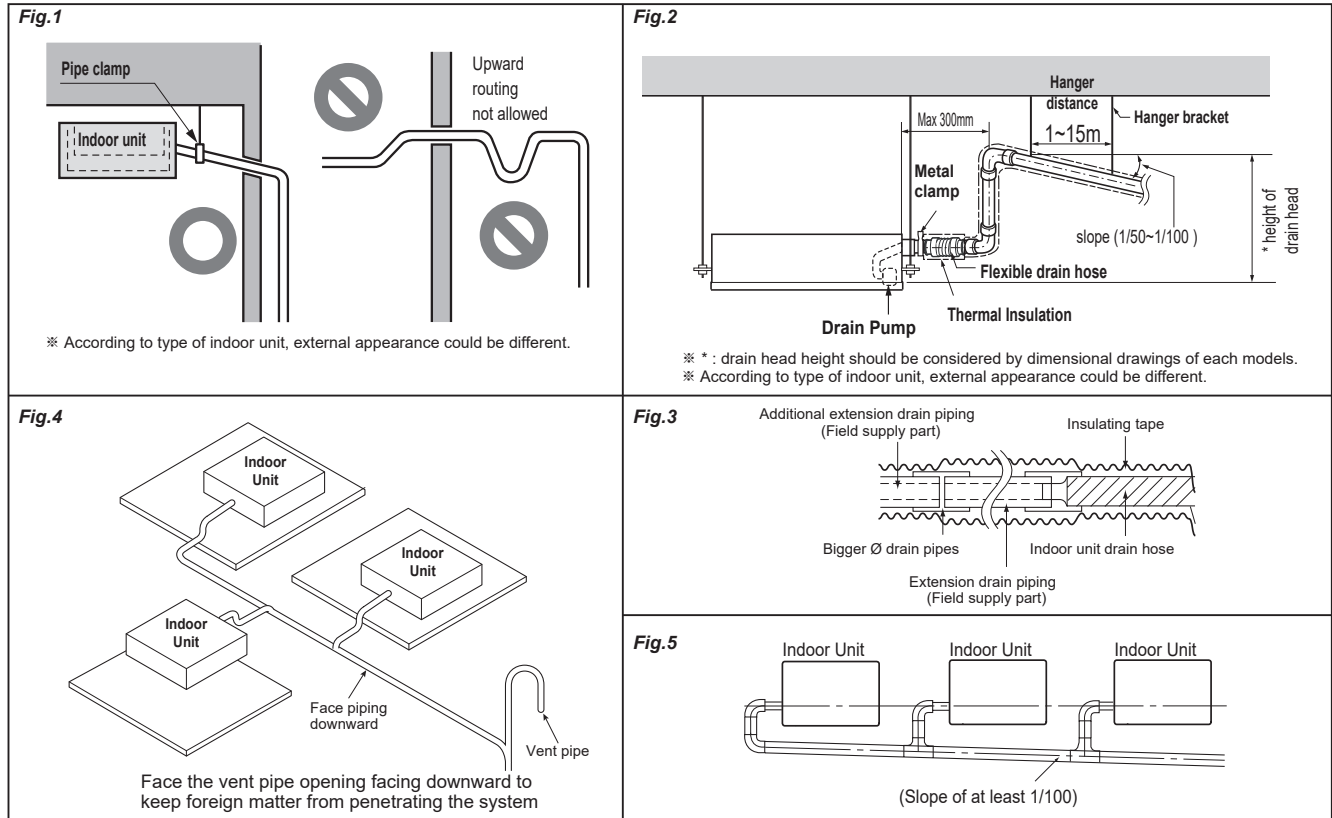

- The drain pipe should be at least equal in size to drain conduit of the indoor unit.
- The drain pipe is thermally insulated to prevent the formation of condensation inside the pipe.
- The drain up mechanism should be fitted before the indoor unit is installed and when the electricity has been connected a little of water should be added to the drain pan and the drain pump to check and see if it is functioning correctly.
- All connections should be secure. (Special care is needed with PVC pipe)

■ Dimension of drain pipe connection [Fig.1, Fig.2]

- Drain piping must have down-slope (1/50 to 1/100). Be sure not to provide up-and-down slope to prevent reversal flow.
- During drain piping connection, be careful not to exert force on the drain port on the indoor unit.
- The outside diameter of the drain connection on the indoor unit and drain piping fittings should be referenced from 'Specifications' of each models.
 - Piping material: Use the Polyvinyl chloride pipe. VP 20 or VP 25 pipe fittings.
- Be sure to install heat insulation on the drain piping.
 - Heat insulation material: Polyethylene foam with thickness more than 8 mm (5/16 inch).
- Possible drain head height is specified to range of 700 ~ 800 mm (27-6/19 ~ 31-1/2 inch). So the drain head should be installed below that (Refer to Dimensional Drawings of each).

■ Connection of an auxiliary(flexible) drain hose [Fig.3]

- To connect drain pipe to the drain socket on the indoor unit, an auxiliary flexible drain hose should be used. Auxiliary flexible drain hose allows that the drain pipe can be connected to the socket without breaking by excessive strain.

< ! > CAUTIONS

- The supplied flexible drain hose should not be curved, neither screwed. The curved or screwed hose may cause a leakage of water.
- It is need to insulate the auxiliary drain hose with thermal insulation material.
 - When extending the drain hose, use a commercially available drain extension hose, and be sure to insulate the extended section of the drain hose which is indoors.
 - Make sure the diameter of the extension drain piping is the same as the indoor unit drain hose size or bigger.

■ Ground drain piping [Fig.4, Fig.5]

- Select diameter of drain piping which adapts to the capacity of the unit connected. The pipe down from the combination should be as large as possible.
- The pipe work should be kept as short as possible and the number of indoor units per group kept to a minimum.
- Face the vent pipe opening facing downward to keep foreign matter from penetrating the system.



Air Solution

LG Electronics Inc, 128, Yeoui-daero,
Yeongdeungpo-gu, Seoul, Korea
(07336)

<http://partner.lge.com>

<http://sedc.lge.com>

Copyright 2022 LG Electronics Inc.
All Rights Reserved.

The air conditioners manufactured by LG have received ISO9001 certificate for quality assurance and ISO14001 certificate for environmental management system.
The specifications, designs, and information in this brochure are subject to change without notice.